

# Resistor Sensitivity to Electrostatic Discharge (ESD)

## Introduction

For most of us, electrostatic discharge (ESD) and static electricity are little more than the shock received when touching a metal doorknob after walking along a carpeted floor, or when opening a car door. The level of the voltage produced depends on a number of factors, such as the affinity of the two bodies and the air humidity, and can reach over 25 000 V. We experience these occurrences of static electricity everyday.

ESD can be defined as a rapid transfer of charge between bodies at different electrical potentials – either by direct contact, arcing, or induction – in an attempt to become electrically neutral. The human threshold for feeling an ESD is 3000 V, so any discharge that can be felt is above this voltage level.

While an ESD does not actually harm the human body, it is possible for electronic devices to be damaged by it, even by a discharge that is under 3000 V. ESD damage can occur at any stage of the part's life, from manufacturing to service. Damage can be caused from handling ESD-sensitive (ESDS) devices without taking precise precautions to eliminate any potential discharges onto them. The most common cause of ESD damage is direct transfer of an electric charge from either a human body or a charged material to an ESDS device.

In resistors, ESD sensitivity is a function of their size. The smaller the resistor, the less space there is to spread the energy pulsed through it from the ESD. This energy concentration in a small area of a resistor's active element causes it to heat up, which could lead to irreversible damage. With the growing trend of miniaturization, electronic devices, including resistors, are becoming smaller and smaller, causing them to be more prone to ESD damage.

ESD damage is generally divided into three categories:

- **Parametric Failure** – the ESD event alters one or more of the device parameters (resistance in the case of resistors), causing it to shift from its required tolerance. This failure does not directly pertain to functionality; thus a parametric failure may be present even if the device is still functional. For example, if a 10 k $\Omega$  resistor with a 1 % tolerance undergoes an ESD event that changes its resistance to 11 k $\Omega$  (10 % deviation), the device would still be able to function as a resistor; however, its altered parameters would no longer be suitable for its original function.

- **Catastrophic Damage** – the ESD event causes the device to immediately stop functioning. This may occur after one or a number of ESD events, and may have many causes, such as human body discharge or the mere presence of an electrostatic field.
- **Latent Damage** – the ESD event causes moderate damage to the device, which is not noticeable, as the device appears to be functioning correctly. However, the load life of the device is dramatically reduced, as further degradation caused by operating stresses may cause the device to fail during service. This defect is of greatest concern as it is very difficult to detect by visual inspection or re-measurement.

Different resistor technologies exhibit various levels of sensitivity to ESD damage. Damage to an ESDS device depends on the device's ability to dissipate energy and withstand the energy of the voltage levels involved, and is generally exhibited by a change in the electrical resistance of the device. This is especially crucial in devices requiring high precision and reliability.

Thin film resistors are composed of a metal layer that is only a few hundred angstroms thick. This severely limits the device's capability to withstand the energy that is passed through it during an electrostatic discharge, causing it to be very sensitive to ESD damage. Thin film resistors are energy dependent and can experience value changes of up to 5 % before the ESD causes the film to rupture (Figure 2).

Thick film resistors are so sensitive to ESD voltages that the application of ESD is sometimes used as a trimming method, as these resistors almost always experience negative resistance changes when exposed to ESD. Applying an ESD can thus have the positive effect of reducing overshooting of the desired resistance. However, this is only useful in the calibration stage of production, and any additional exposure to ESD after calibration can cause a resistance change of over 50 %, which would obviously be a large deviation from the desired resistance tolerance.

Foil-based resistors have a number of characteristics that make them superior to both thin and thick film when it comes to withstanding ESD. For one thing, foil is 100 times thicker than thin film, and therefore the heat capacity of the resistive foil layer is much higher compared to the thin film layer.

### Resistor Sensitivity to Electrostatic Discharge (ESD)

#### ESD Test on Surface Mount Chip Resistors

By using an electrolytic 500 pF capacitor charged up to 4500 V, pulses were performed on a number of 10 kΩ resistors (metric size RR3216M, inch size RR1206), with an initial voltage spike of 2500 V (Figure 1). The unit was allowed time to cool down, after which the resistance measurement was taken and displayed in ppm deviation from the initial reading. Readings were then taken in 500 V increments up to 4500 V.

Figures 2, 3, and 4 show the resistance shift after increasing ESD voltage pulses. The foil chips (Figure 4) show no measurable shift.

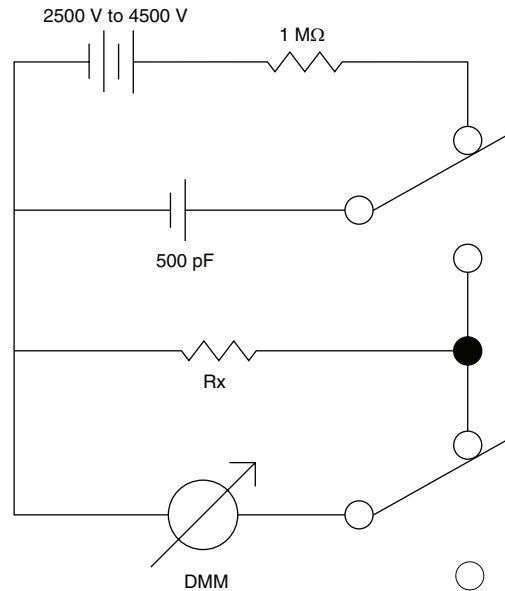

Figure 1.

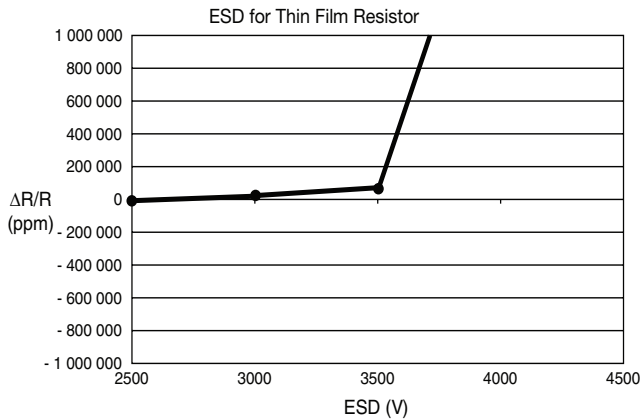

Figure 2.

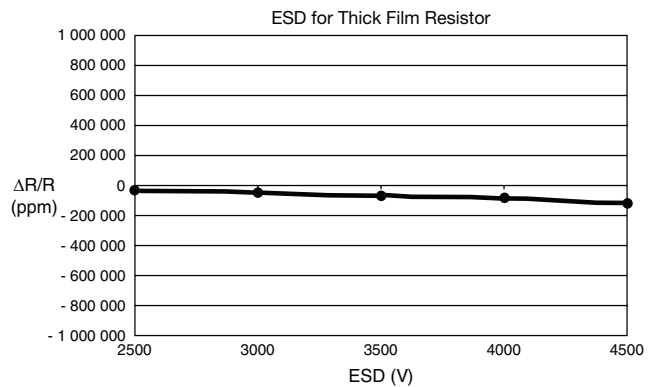

Figure 3.

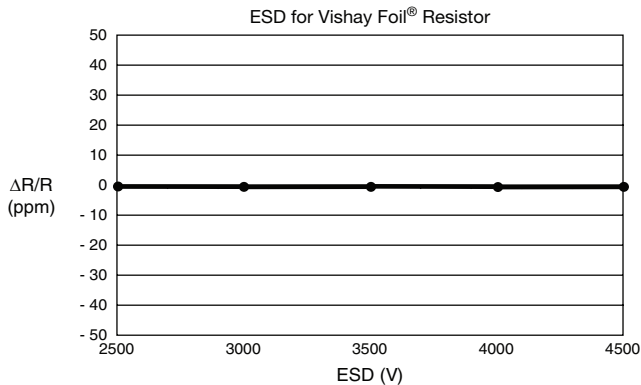

Figure 4.

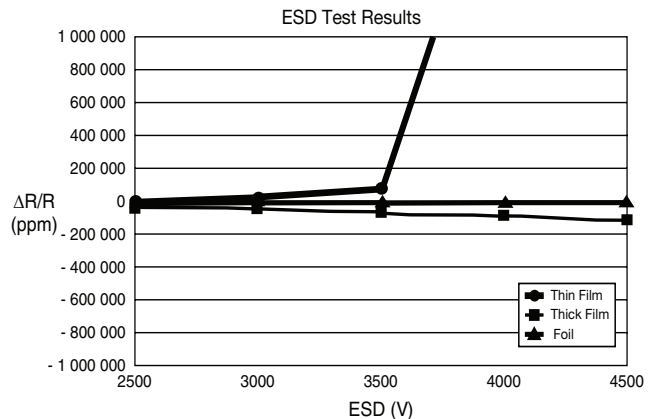

Figure 5.

## Resistor Sensitivity to Electrostatic Discharge (ESD)

### Conclusions

The superiority of Bulk Metal<sup>®</sup> foil precision resistors over thin film, when subjected to ESD, is attributed mainly to their greater thickness (foil is 100 times thicker than thin film), and therefore the heat capacity of the resistive foil layer is much higher compared to the thin film layer. Thin film is created through particle deposition processes (evaporation or sputtering), while foil is a bulk alloy with a crystalline structure created through hot and cold rolling of the melt.

Tests performed have indicated that foil chip resistors can withstand ESD events above 25 000 V (data available), while thin film chip resistors have been seen to undergo catastrophic failures at electric potentials as low as 3000 V (parametric failures at even less). If the application is likely to confront the resistor with ESD pulses of significant magnitude, the best resistor choice is Foil.

The Current Path in a Thin Film Resistor  
Particle-to-Particle Matrix

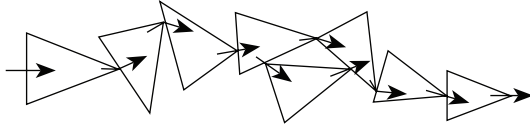

Figure 6.

The Current Path in a Bulk Metal<sup>®</sup> Foil Resistive Alloy

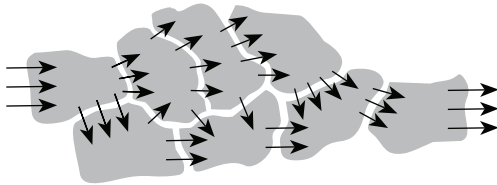

Figure 7.