

DESCRIPTION

The SL339 consists of four independent voltage comparators. These were designed specifically to operate from a single power supply over a wide range of voltages. Operation from split power supplies is also possible and the low power supply current drain is independent of the magnitude of the power supply voltage. The outputs can be connected to other open-collector outputs to achieve wired-AND relationships.

FEATURES

- ◆ Wide supply voltage range
- ◆ Low supply current drain independent of supply voltage.
- ◆ Low input biasing current
- ◆ Low input offset current
- ◆ Low input offset voltage
- ◆ Input common-mode voltage range includes GND
- ◆ Differential input voltage range equal to the power supply voltage.
- ◆ Low output saturation voltage
- ◆ Output voltage compatible with TTL, MOS and CMOS logic.

PIN CONFIGURATION – Top View

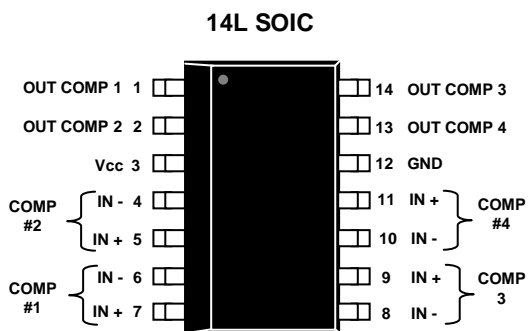

PACKAGE TOP MARKING:

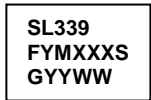

- Line 1: Device
- Line 2: Lot No. Code
F – Foundry Code (C)
YMXXX – 5 Character Lot No.
S – Split Code
- Line 3: Date Code
G – Assembly Vendor Code
YY – Year
WW – Workweek

ORDERING INFORMATION

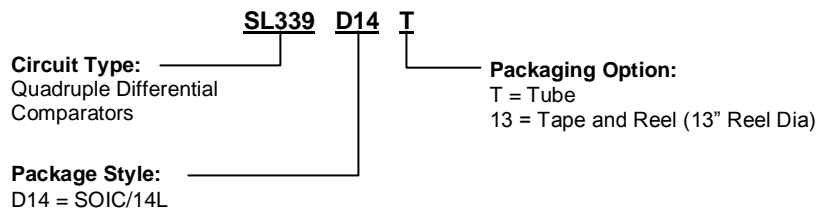



ELECTRICAL CHARACTERISTICS

at specified free-air temperature, $V_{CC} = 5V$ (unless otherwise noted)

PARAMETER	TEST CONDITIONS*		MIN	TYP	MAX	UNIT
V_{IO} Input offset voltage	$V_{CC} = 5V$ to $30V$ $V_{IC} = V_{ICRmin}$, $V_O = 1.4V$	25 °C		2	5	mV
		Full range			9	
I_{IO} Input offset current	$V_O = 1.4V$	25 °C		5	50	nA
		Full range			150	
I_{IB} Input bias current	$V_O = 1.4V$	25 °C		-25	-250	nA
		Full range			-400	
V_{ICR} Common-mode input voltage range**		25 °C	0 to $V_{CC} - 1.5$			V
		Full range	0 to $V_{CC} - 2$			
A_{VD} Large-signal differential voltage amplification	$V_{CC} = 15V$, $V_O = 1.4V$ to $11.4V$, $R_L \geq 15k\Omega$ to V_{CC}	25 °C	50	200		V/mV
I_{OH} High-level output current	$V_{OH} = 5V$, $V_{ID} = 1V$	25 °C		0.1	50	nA
	$V_{OH} = 30V$, $V_{ID} = 1V$	Full range			1	μA
V_{OL} Low-level output voltage	$I_{OL} = 4mA$, $V_{ID} = -1V$	25 °C		150	400	mV
		Full range			700	
I_{OL} Low-level output current	$V_{OL} = 1.5V$, $V_{ID} = -1V$	25 °C	6			mA
I_{CC} Supply current	$R_L = \infty$	$V_{CC} = 5V$	25 °C	0.8	2	mA
		$V_{CC} = 30V$	Full range		2.5	

* Full range (MIN to MAX), for the SL339 is 0 °C to 70 °C. All characteristics are measured with zero common-mode input voltage unless otherwise specified.

** The voltage at either input or common-mode should not be allowed to go negative by more than 0.3V. The upper end of the common-mode voltage range is $V_{CC} - 1.5V$, but either or both inputs can go to 30V without damage.

SWITCHING CHARACTERISTICS, $V_{CC} = 5V$, $T_A = 25 °C$

PARAMETER	TEST CONDITIONS		MIN	TYP	MAX	UNIT
Response time	R_L connected to 5V through 5.1 k Ω $C_L = 15pF$ * (See Note 1)	100-mV input step with 5-mV overdrive		1.3		μs
		TTL-level input step		0.3		

* C_L includes probe and jig capacitance.

NOTE 1: The response time specified is the interval between the input step function and the instant when the output crosses 1.4V.



14L-SOIC PACKAGE DIMENSION

14-Lead SOIC Plastic
Surface Mounted Package
SLI Package Code: D14

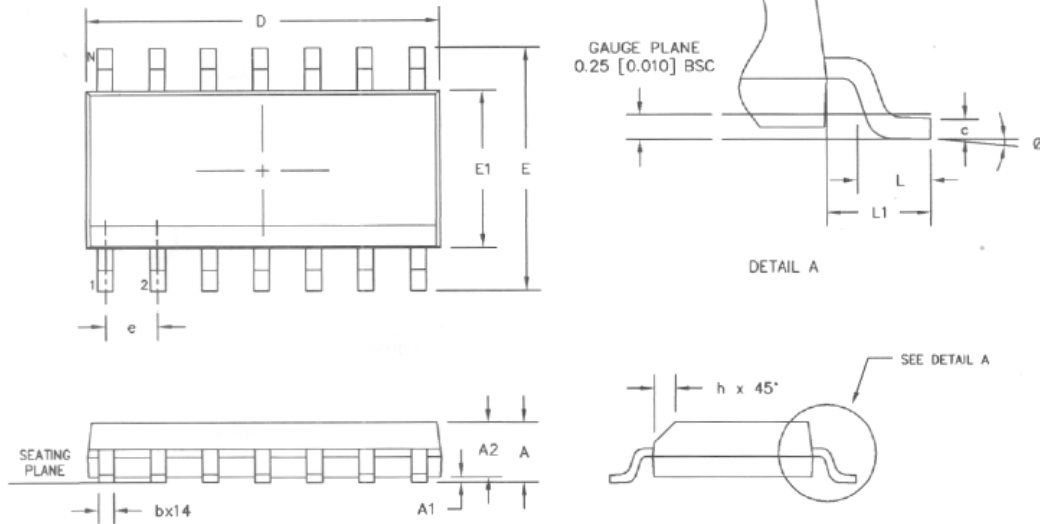

NOTES:

1. DIMENSION D DOES NOT INCLUDE MOLD FLASH, PROTRUSIONS OR GATE BURRS. DIMENSION E1 DOES NOT INCLUDE INTERLEAD FLASH OR PROTRUSIONS.
2. COPLANARITY APPLIES TO THE TERMINALS. COPLANARITY SHALL NOT EXCEED 0.004" [0.10 mm].
3. BASED FROM JEDEC MS-012 VARIATION AB.

SYM	DIMENSION IN INCHES			DIMENSION IN MM		
	MIN	NOM	MAX	MIN	NOM	MAX
A	0.053	0.060	0.069	1.35	1.52	1.75
A1	0.004	0.007	0.010	0.10	0.18	0.25
A2	0.050	0.053	0.056	1.27	1.35	1.42
b	0.014	0.016	0.019	0.36	0.41	0.48
c	0.007	0.008	0.010	0.18	0.20	0.25
D	0.336	0.340	0.344	8.53	8.65	8.73
E1	0.150	0.154	0.158	3.81	3.90	4.01
E	0.232	0.239	0.244	5.89	6.07	6.19
e	0.050			1.27		
L	0.020	-	0.032	0.51	-	0.81
L1	0.039	0.043	0.047	0.99	1.09	1.19
Ø	0*	-	8*	0*	-	8*
h	0.011	0.015	0.019	0.28	0.38	0.48

PACKAGE MECHANICAL DRAWING

**Surface Mountable Tape & Reel Specifications in mm (inch)
(SOIC)**

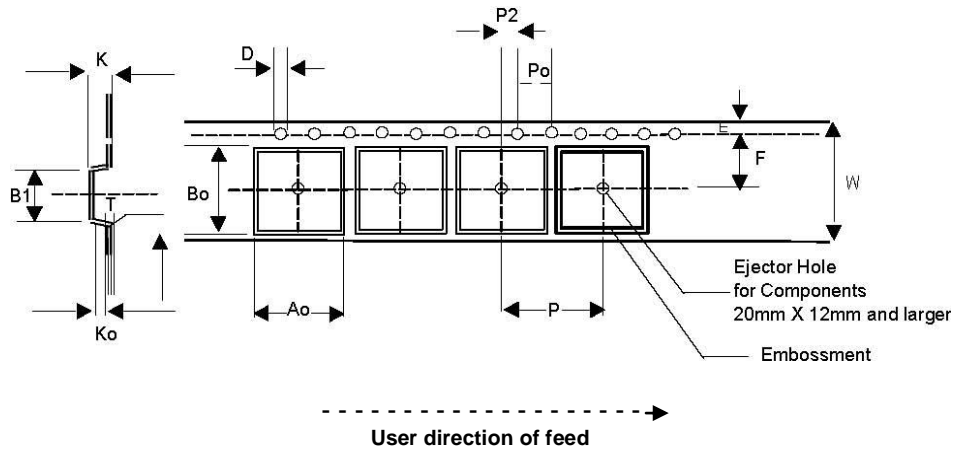

Tape Size (W)	D	E	P0	T (Max)	A0, B0, K0	T1 (Max)	Constant Dimensions
8, 12, 16, 24mm	1.55±0.05 (.061±.002)	1.75±0.10 (.069±.004)	4.0±0.10 (.157±.004)	0.400 (.016)	See Note	0.100 (.004)	

Tape Size (W)	B1 Max.	D1 Min.	F	K Max.	P2	
8 mm	4.2 (.165)	1.0 (.039)	3.5±0.05 (.138±.002)	2.4 (.094)	2.0±.05	
12 mm	8.2 (.323)	1.5 (.059)	5.5±0.05 (.217±.002)	4.5 (.177)	.079±.002	Variable Dimensions

Per Package Requirement					
Components	Tape Width (W) mm	Cavity Pitch (P) mm	Devices per Reel		
			7" Reel	13" Reel	
SOIC 14L	16	8	-	2500	

Note: Ao Bo Ko are determined by component size. The clearance between the component and the cavity must be within 0.05 [.002] min. to 0.50 [.020] max. for 8mm tape, 0.05 [.002] min to 0.65 [.026] max for 12mm tape.

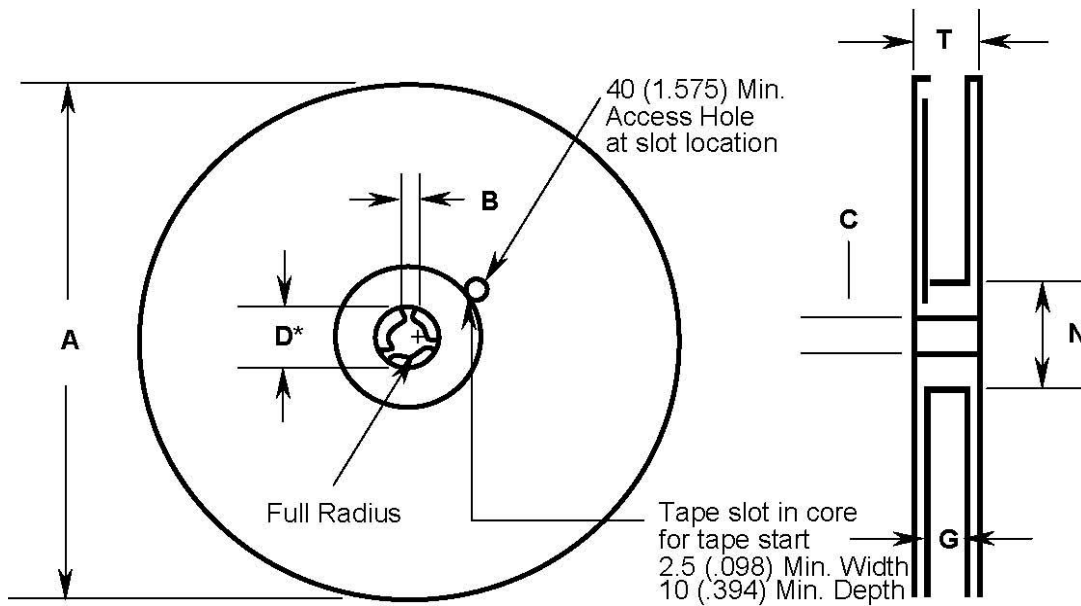

REEL DIMENSIONS							
Tape Size	A Max.	B Min.	C	D* Min.	N Min.	G	T Max.
8mm	330 (12.992)	1.5 (.059)	13.0±0.20 (.152±.008)	20.2 (.795)	50 (1.973)	8.4±1.5 0.0 (.331±.059) 0.0	14.4 (.567)
12mm	330 (12.992)	1.5 (.059)	13.0±0.20 (.152±.008)	20.2 (.795)	50 (1.973)	12.4±2.0 0.0 (.488±.078) 0.0	14.4 (.567)

MECHANICAL POLARIZATION

SOIC-14L DEVICE

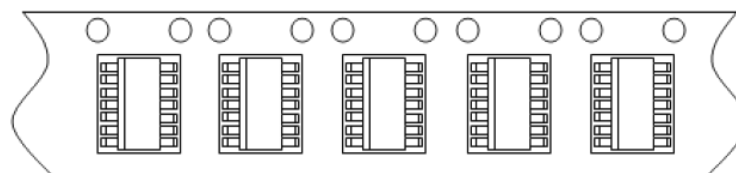

User direction of feed - - - - ->