

# OMMIC

## Short Form Catalog 2014

GM SYSTEMS  
27 KIM PLACE  
KINGS PARK, NEW YORK 11754  
LAND LINE: 631-269-3820  
CELLPHONE: 516-807-9488 (Old Aeroflex Cell Number)  
Email: t2@gmsystems.com

**MMIC products from 500MHz to 160GHz** PAGE 4-10

**Advanced GaAs, InP, GaN processes** PAGE 13-17

**Epitaxy services** PAGE 14

**Foundry and FAB+ services** PAGE 15-17

**Design Center for state of the art custom MMICs** PAGE 19-21

**Space Heritage and Space qualification services** PAGE 23-26

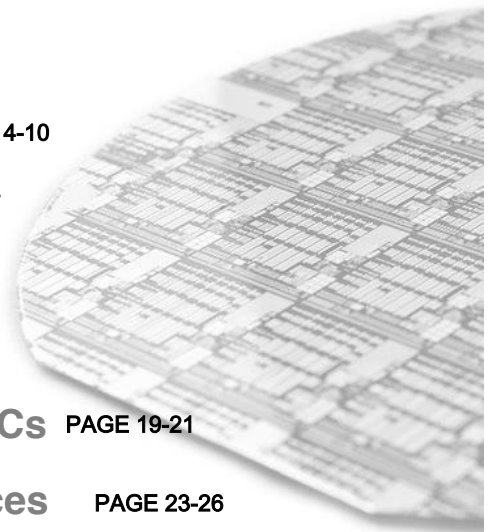

# Innovating with III-V's

## GaAs-InP-GaN Solution Leading Supplier

### OMMIC in few words

OMMIC, based near Paris in France, is a leading supplier of Epitaxy, Foundry Services and MMICs based around the most advanced III-V processes.

OMMIC is exploiting its more than 30 years background in III-V Materials, Design and Processing to provide innovative solutions enabling its customers to be leaders in a more and more demanding market place.



OMMIC is a supplier of MMIC circuits, Foundry Service and Epitaxial Wafers based on III-V (GaAs, GaN and InP) materials. As a leader in advanced technologies, OMMIC provides its customers with cutting edge performance for Telecommunication, Space and Defense Applications.

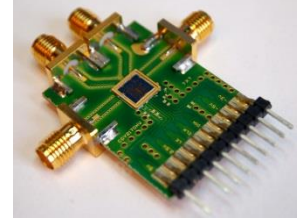

### OMMIC: Flexible, customer oriented with a strong Quality Policy

OMMIC operates in a highly competitive global market and must be competitive and responsive.

OMMIC has been ISO 9001 certified since 1994 and ISO 14001 since 2002.

This sustainable commitment is fully supported by its quality management system. All our actions are global and do take into the following areas of improvement.

#### OMMIC is focused on

- Innovation and development through the establishment of partnerships with our customers, agents and suppliers.
- Compliance with the requirements of our customers and with the European regulation.
- Development of staff skills, responsible and motivating human policy.
- Minimize our impact on the environment through preventive action plans.



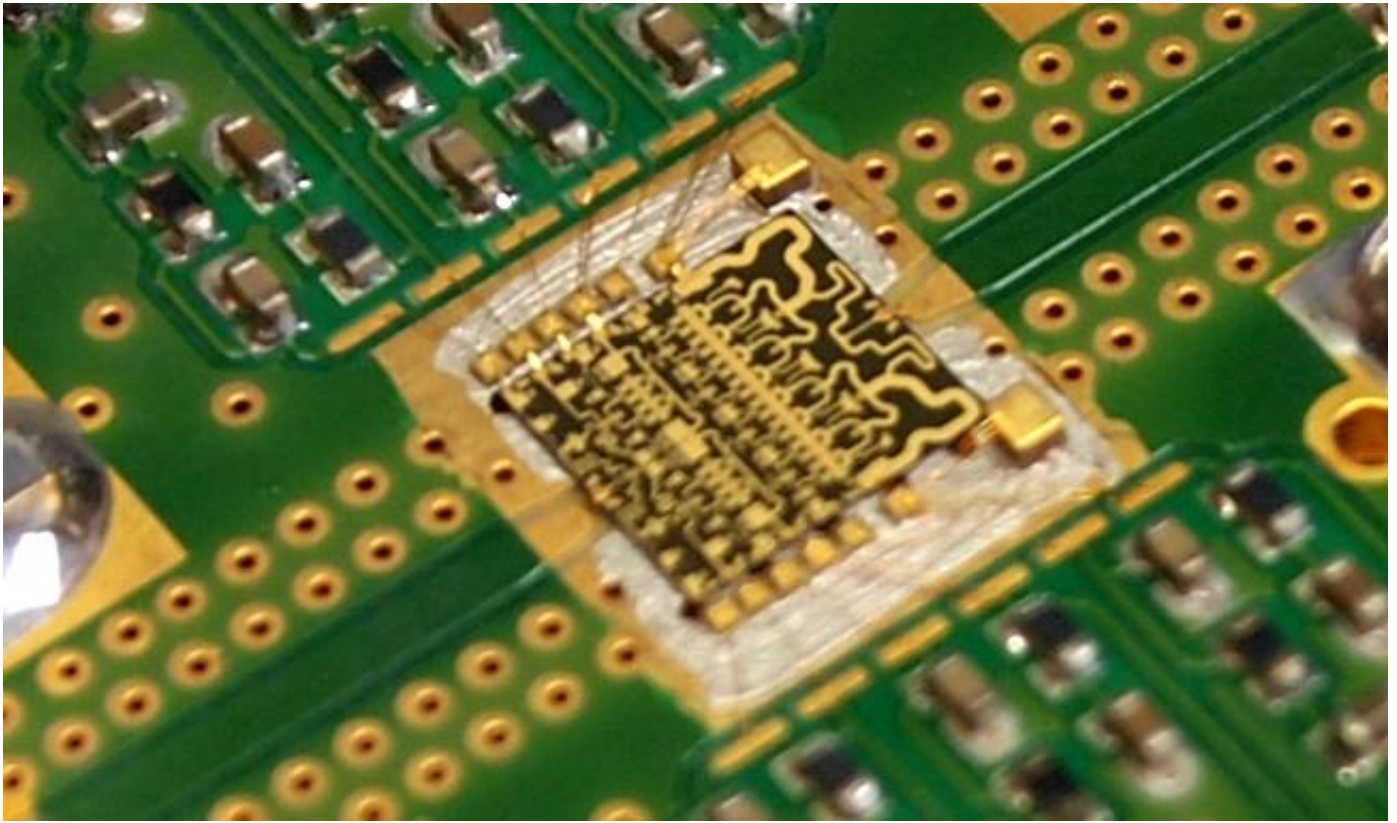

# OMMIC

## MMIC Products Selector Guide

Ultra Low Noise Amplifiers ( 0.5 - 6GHz ) **PAGE 4-5**

Low Noise Amplifiers ( 5 - 160GHz ) **PAGE 4-5**

Power Amplifiers ( 8 - 46GHz ) **PAGE 6-7**

Wideband Amplifiers ( DC - 54GHz ) **PAGE 6-7**

Digital Attenuators and Phase shifters ( 5 - 35GHz ) **PAGE 10**

Corechip and Control functions ( 5 - 35GHz ) **PAGE 8-10**

Mixers ( 0.1 - 10GHz )

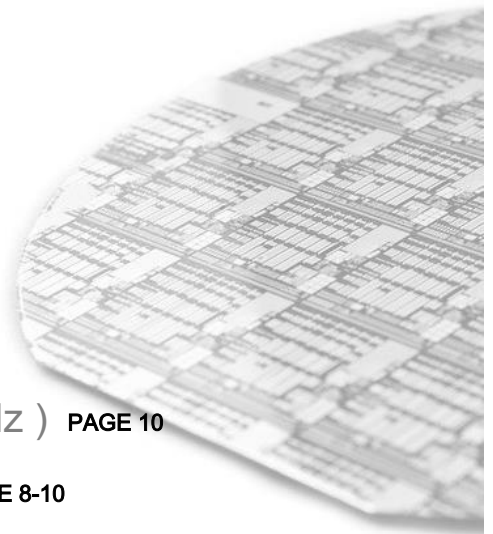

OMMIC Portfolio of MMICs, includes LNA from 5 to 160GHz for civil application such as Telecommunication, Passive imaging, Radars but also for space and military applications.

- LNA are manufactured using OMMIC 135nm gate length PHEMT Technology (D01PH) or 70nm MHEMT (D007IH) Technology.
- The MMICs use gold bonding pads, backside metallization and are fully protected with Silicon Nitride passivation to obtain the highest level of reliability.
- **D01PH** technology has been evaluated for Space applications and is on the **(EPPL)**,European Preferred Parts List of the **(ESA)** European Space Agency.



**Performance Table for Ultra Low Noise Amplifiers**

OMMIC Ultra Low Noise Amplifiers are dedicated to applications such as Base Station Rx architectures thanks to a very low noise and high OIP3 from L to S bands. Standards targeted are GSM, CDMA2000, WCDMA, LTE, LTE-A.

Part number	Operation Frequency (GHz)	Gain (dB)	Noise figure (dB)	OIP3 (dBm)	Bias (V)	Current (mA)	Package	Status
CGY2105XHV	0,5 - 4	19	0,42	33	5	2 x 50	QFN 4x4	Production
CGY2106XHV	0,2 - 5	21	0,45	33	5	2 x 60	QFN 4x4	Production
CGY2107HV	0,5 - 6	21	0,6	34	5	2 x 50	QFN 4x4	OBSOLETE
CGY2108HV	0,5 - 6	22	0,6	36	5	2 x 50	QFN 4x4	Production
CGY2108GS	0,5 - 6	21	0,6	36	5	2 x 50	Flight Model	Production
CGY2109HV	0,5 - 3	20	0,72	32	5	2 x 50	QFN 4x4	Production

**Performance Table for Low Noise Amplifiers MMIC**

OMMIC LNA MMIC are suitable for nowadays satellite, radar, and passive imaging application thanks to very low noise performances

Part number	Operation Frequency (GHz)	Gain (dB)	Noise figure (dB)	OP1dB (dBm)	Bias (V)	Current (mA)	Package	Status
CGY2178UH/C1	5 - 6	30	1	15	3	40	Die	Production
CGY2178HV/C1	5 - 6	30	1,1	15	3	40	QFN	Sampling
CGY2120XUH/C1	5 - 7	13,2	0,5	12	1	50	Die	Production
CGY2124UH/C1	8 - 12	32	1,1	10	5	55	Die	Production
CGY2124HC/C1	8 - 12	32	1,5	10	5	55	HTCC QFN	Sampling
CGY2125UH/C1	13 - 15	25	1,5	8	3,3	20	Die	Production
CGY2121XUH/C1	18 - 26	17,5	1,2	5	0,8	60	Die	Production
CGY2128UH/C1	24 - 34	24	1,3	11	3,5	47	Die	Production
CGY2122XUH/C1	25 - 43	32	1,5	1,2	1,1	30	Die	Production
CGY2123UH/C1	32 - 38	22	2,3	13	5	65	Die	Production
CGY2190UH/C1	70 - 110	23	3	1	1	33	Die	Production
CGY2191UH/C2	100 - 160	20	4	3	1,4	42	Die	Sampling

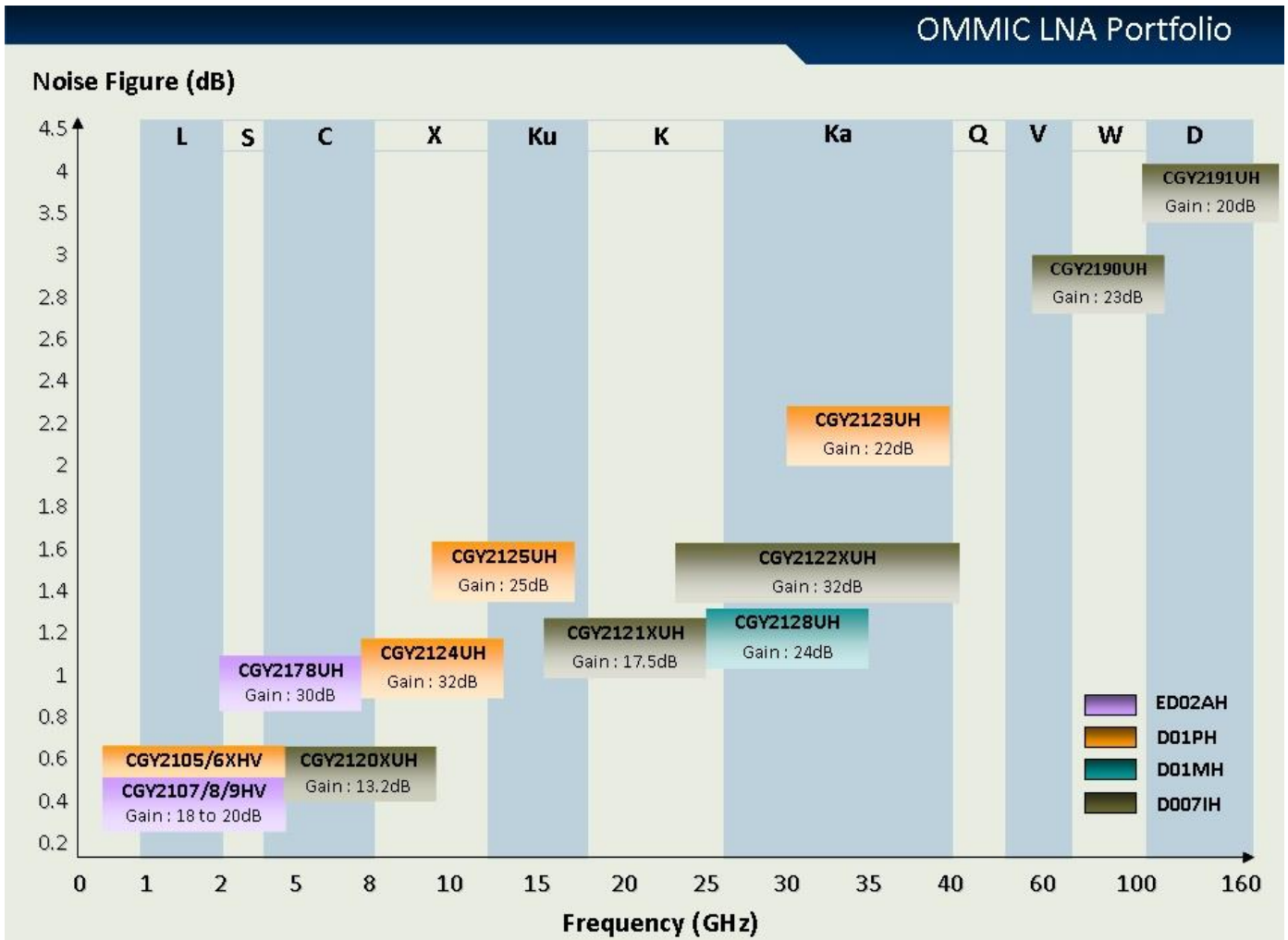

**CGY2105XHV/06XHV/07HV/09HV**

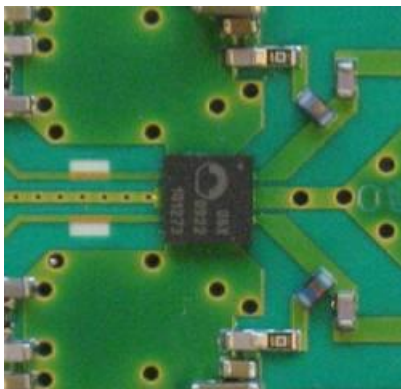

500MHz – 6GHz NF : 0.5dB  
20dB gain

**CGY2124UH/C1**

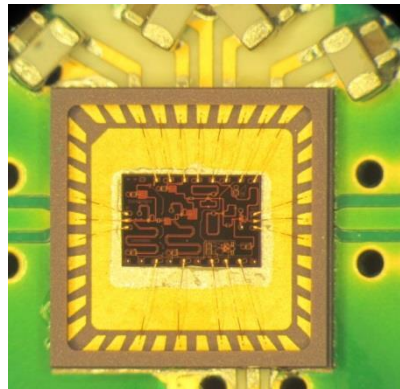

8 – 12GHz NF : 1.4dB  
Single supply

**CGY2122XUH/C2**

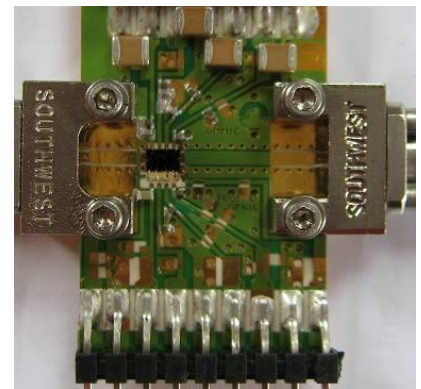

25 – 43GHz NF : 1.5dB  
32 dB Gain

OMMIC Portfolio of MMICs, includes Power Amplifiers from 8 to 46GHz for civil application such as Telecommunication, Instrumentation, Radars but also for Satcom and military applications.

- Power amplifiers are manufactured using OMMIC 135nm gate length PHEMT Technology **D01PH** or 125nm MHEMT Technology **D01MH**.

Performance Table for Power Amplifiers								
OMMIC Power Amplifier are dedicated to application such as Radar, telecommunication and instrumentation.								
Part number	Operation Frequency (GHz)	Gain (dB)	Saturated Power (dBm)	Compression point P1dB (dBm)	Bias Voltage (V)	Bias Current (A)	Package	Status
CGY2139MUH/C1	8 - 12	22	23	22	8	0,1	DIE	Production
CGY2139PUH/C1	8 - 12	19	27	26	7	0,18	DIE	Production
CGY2139AUH/C1	8 - 12	23	40,5	39,6	8,5	3,9	DIE	Production
CGY2139AUH/C2	8 - 12	25	41	40,1	8,5	4,9	DIE	Production
CGY2134UH/C1	18 - 23	28	22	21	4,5	0,3	DIE	Production
CGY2135UH/C1	18 - 23	19	33,1	32,3	4,0	1,2	DIE	Production
CGY2138UH/C1	27,5 - 31	20	37	36	4,5	5,6	DIE	Production
CGY2130UH/C1	37 - 41	22	27	26	4,5	0,63	DIE	Production
CGY2132UH/C1	37 - 41	19	30	29,3	4,5	1,45	DIE	Production
CGY2131UH/C1	39 - 44	22	27	26,2	4,5	0,57	DIE	Production
CGY2133UH/C1	39 - 44	19	30	28	4,5	1,33	DIE	Production
CGY2136UH/C1	40 - 46	20	33,5	33	4,5	2,6	DIE	Production

The MMICs use gold bonding pads and backside metallization and are fully protected with Silicon Nitride passivation to get the highest level of reliability. **D01PH** technology has been evaluated for Space applications and is on the European Preferred Parts List of the European Space Agency.

Wideband amplifiers are manufactured using OMMIC 135nm gate length PHEMT Technology **D01PH** or 125nm MHEMT Technology **D01MH**.

Performance Table for Wideband Amplifiers								
OMMIC Wideband Amplifiers are dedicated to application such as Instrumentation, Electronic warfare, 43 Gb/s OC-768 EAM Driver								
Part number	Operation Frequency (GHz)	Gain (dB)	NF (dB)	Compression point P1dB (dBm)	Bias Voltage (V)	Bias Current (mA)	Package	Status
CGY2141UH/C1	DC - 46	16	2	21	5	195	DIE	Production
CGY2144UH/C2	DC - 54	13	2,5	15	5	100	DIE	Production
CGY2145UH/C1	0,5 - 45	12,7	1,8	18	5	85	DIE	Production
CGY2160UH/C1	1,5 - 47	14,5	2,5	17	5	103	DIE	Production

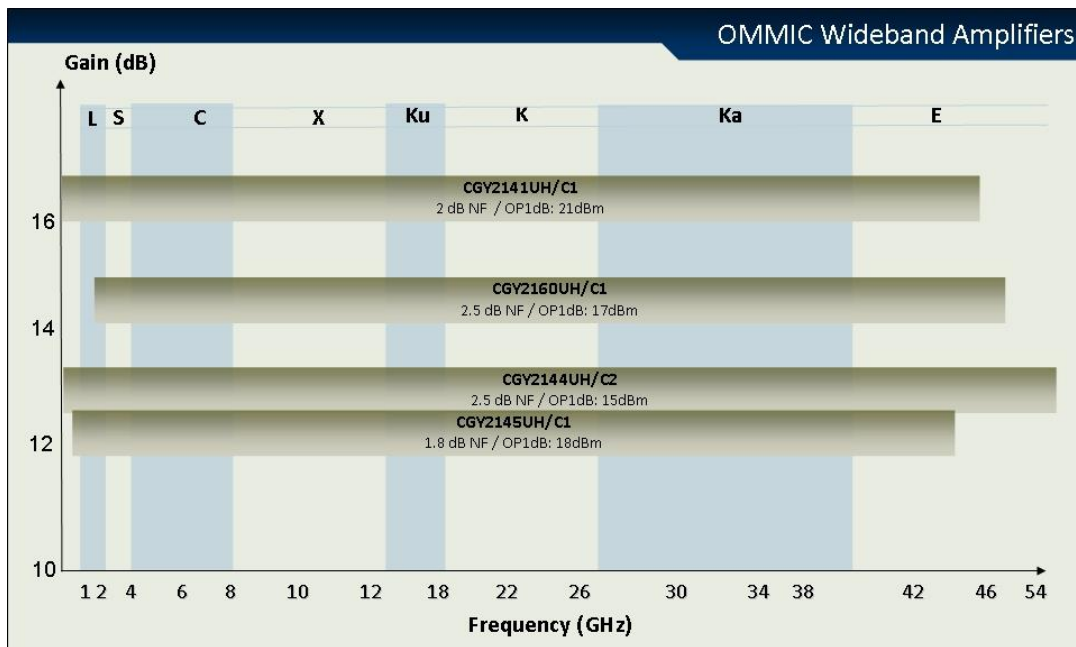
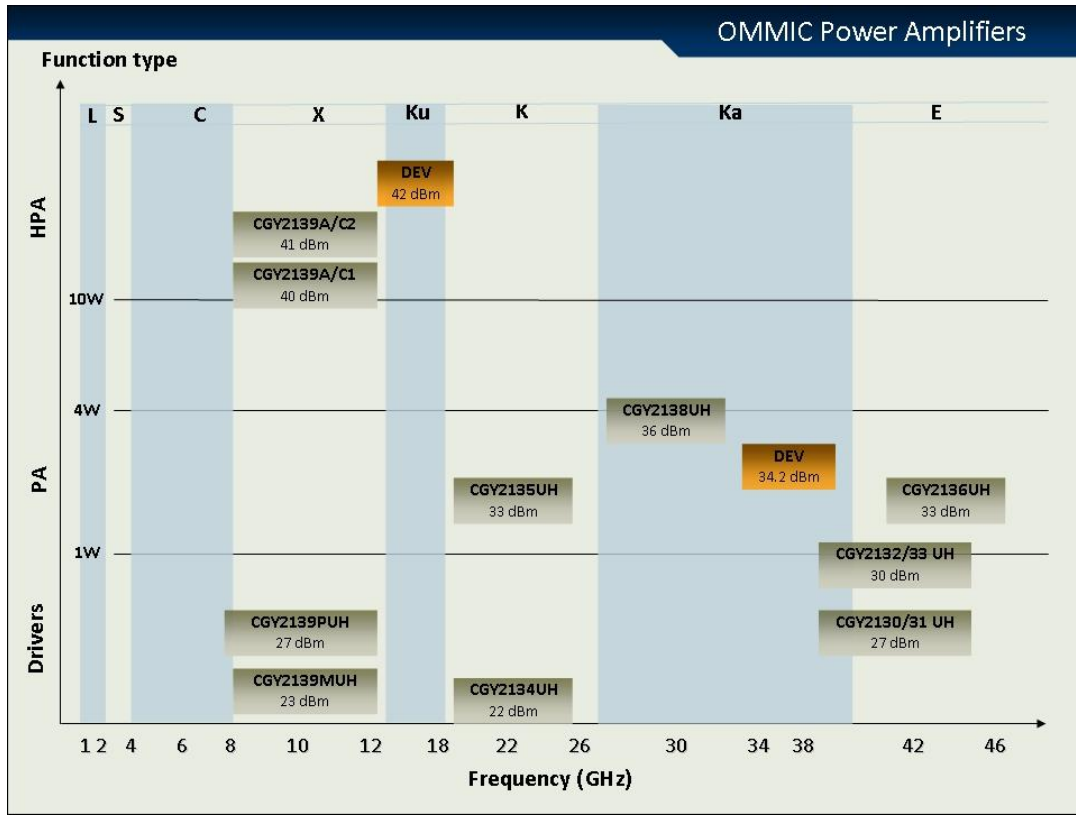

OMMIC Portfolio of MMICs, includes Corechip and control functions.

Corechips are based on the **integration in a single die of Digital Phase Shifters, Digital Attenuators , LNA , MPA and Switches** for phased array antenna applications. Phases and attenuation states are controlled through a single digital data serial input using OMMIC's E/D technology (ED02AH), enabling integration of **a Serial to Parallel interface on the die (SIPO)**.

**OMMIC SIPO stands for Serial Input Parallel Output**

**What is the issue without a SIPO integrated on the die ?**

If not using a SIPO, you need to control each phase state and attenuation state through a parallel control.

This mean many wires in parallel and very bad integration

For example for a 12 bit corechip ( 6 bit phase shifter + 6 bit attenuator) the user will need at least 24 bonding wires to control each states.

To solve serial interface issue some supplier provide external serial converter dies in CMOS but this doesn't solve integration issue due to large amount of bonding between CMOS die and phase + attenuator die

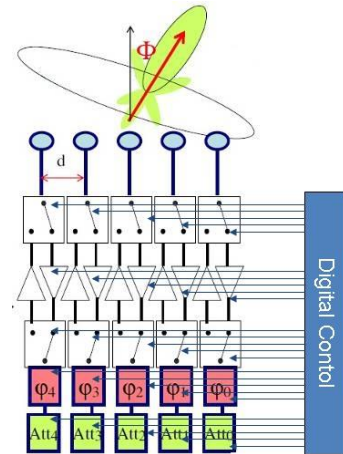

**What is the advantage of OMMIC ED02AH Process ?**

Thanks to its ED02AH process , OMMIC can integrate in the same MMIC , enhanced and depletion transistors. Depletion transistors can be used for analog function such as phase shifter and attenuators.

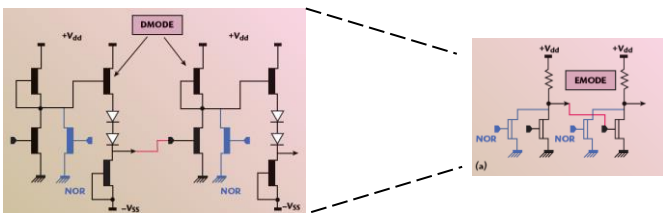

Enhanced transistors help to simplify and better integrate digital functions.

This enable OMMIC to integrate on the MMIC , the SIPO. Then the Corechip or Multifunction chip can be controlled in serial mode with only 3 wire ( Data input , Clock and Latch enable

**OMMIC solution for highly integrated control functions ?**

Each phase and attenuation states are loaded in the shift register at a clock rate up to 250MHz then phase and attenuation configuration is done after latch enable (LE)

**CGY2170XUH ( 6 bit X band corechip)**

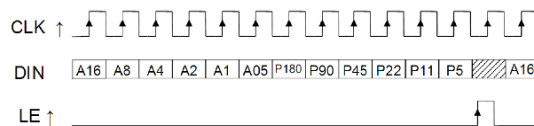

**Less than 4x4mm<sup>2</sup>**

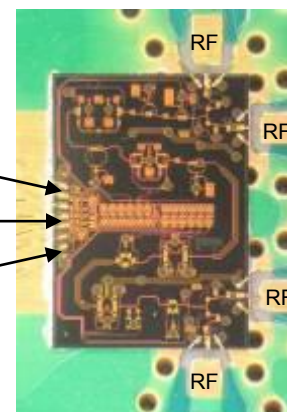



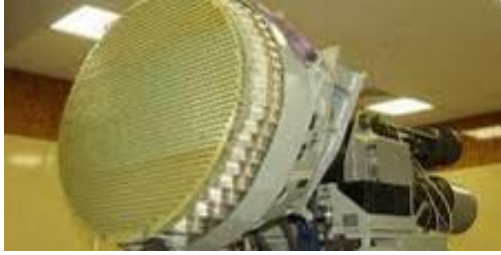

CGY2175AUH/C1 : 3 ports – 6bits  
External LNA and PA

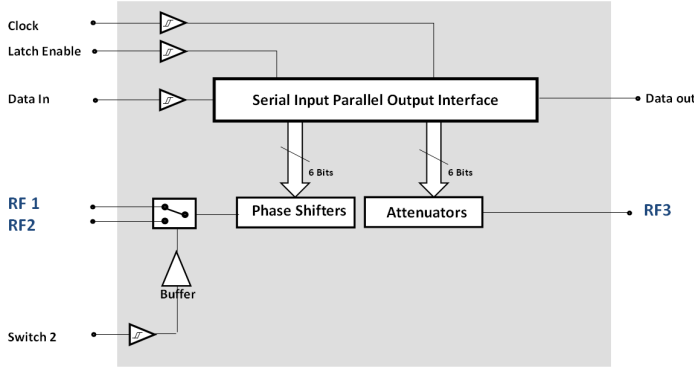

CGY2170UH/C2 : 4 ports – 7bits  
Internal LNA and PA

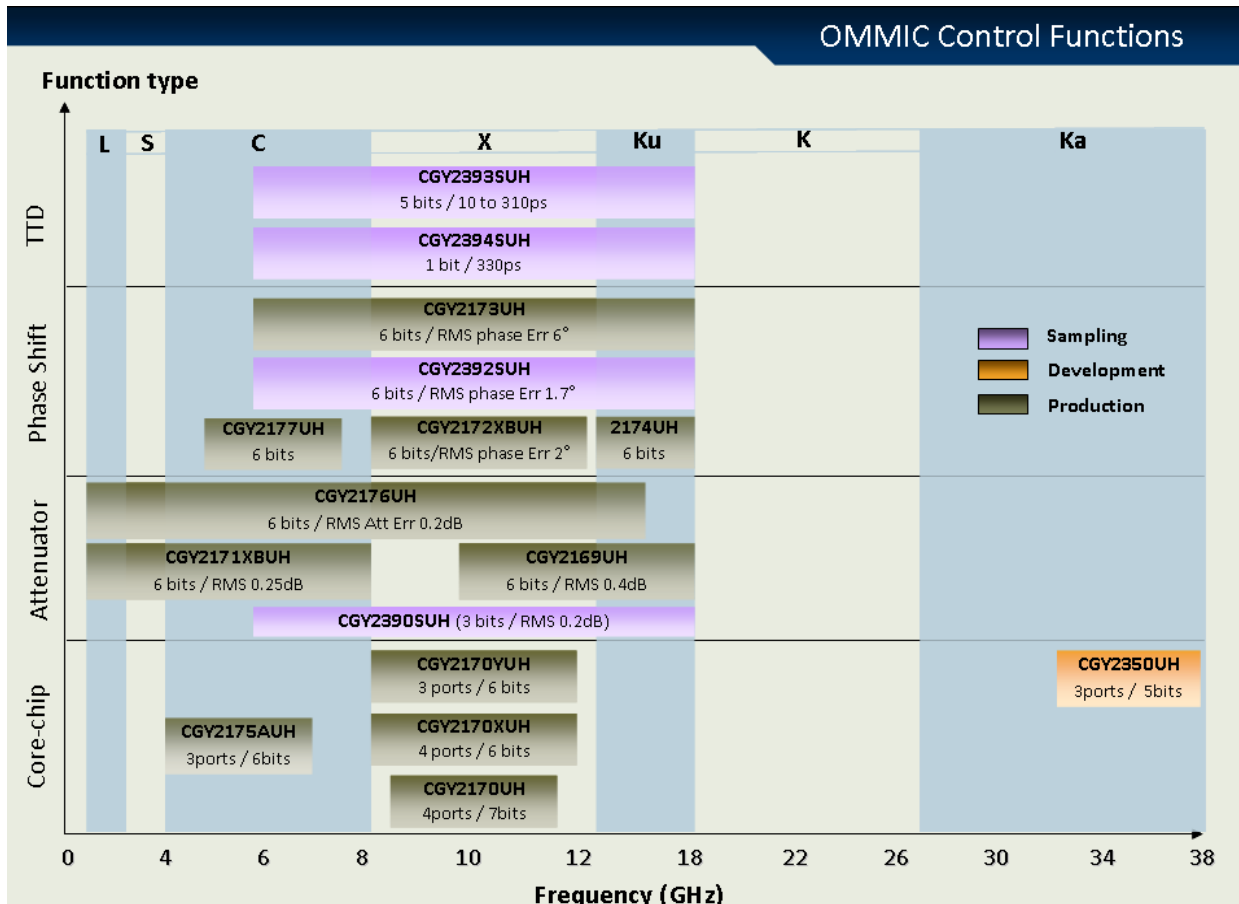
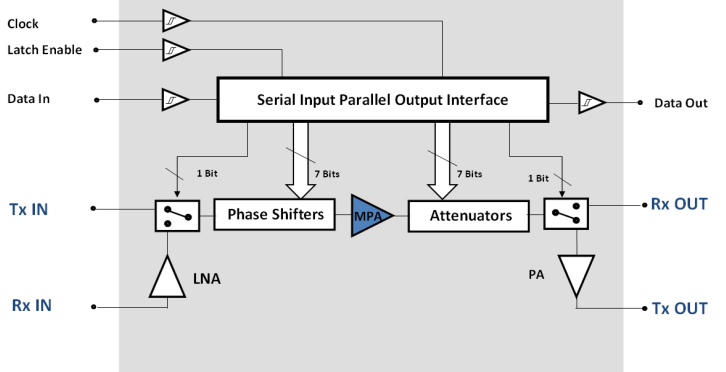

Corechip and control function are manufactured using OMMIC 180nm gate length **ED02AH** E/D PHEMT Technology which is space qualified by ESA.

Performance Table Integrated Corechip functions								
Phase shifter, Attenuators, LNA and MPA integrated into a single chip <b>controlled through Serial CMOS TTL compatible access</b>								
Part number	Operation Frequency (GHz)	Resolution (bits)	Topology	Ctrl Ranges (dB / °)	RMS Atten/Phase Error (dB/°)	Ctrl interface (V)	Package	Status
CGY2175AUH/C1	4,5 - 6,5	6	3 ports	31,5 / 360	0,2 / 1,3	0 / +5	Die	Production
CGY2175BUH/C1	4,5 - 6,5	6	4 ports	31,5 / 360	0,3 / 1,8	0 / +5	Die	Production
CGY2170UH/C2	8,5 - 11,5	7	4 ports	24,7 / 360	0,25 / 5	0 / +5	Die	Production
CGY2170XUH/C2	8 - 12	6	4 ports	31,5 / 360	0,3 / 3	0 / +3	Die	Production
CGY2170XHC/C2	8 - 12	6	4 ports	31,5 / 360	0,3 / 3	0 / +3	HTCC QFN	Sampling
CGY2170YUH/C1	8 - 12	6	3 ports	31,5 / 360	0,4 / 3	0 / +3	Die	Production
CGY2350UH/C1	34 - 36	5	3 ports	31,5 / 360	2 / 8	0 / +3	Die	Development

Part number	Operation Frequency (GHz)	Resolution (bits)	Topology	Gain/Noise (dB)	RMS Phase Error (dB)	Ctrl interface (V)	Package	Status
Phase shifter + LNA integrated in one die for internet over satellites Rx phased array antenna application								
CGY2179UH	10,7 - 12,75	4	2 ports	12 / 1,9	7	0 / +5	Die	Production
CGY2179HV	10,7 - 12,75	4	2 ports	12 / 2	7	0 / +5	QFN 4x5	Production

For system integrators who want to **separate attenuation and phase shifting control** OMMIC do offer stand alone functions of Digitally controlled attenuators, Digitally controlled Phase shifter or Digitally controlled True Time Delay.

Performance Table for Digital Phase Shifters functions								
Part number	Operation Frequency (GHz)	Resolution (bits)	Insertion Loss (dB)	Phase Range (°)	RMS Phase Error (°)	Ctrl interface (V)	Package	Status
CGY2177AUH/C1	4,8 - 6,8	6	5	360	2	0 / +5	Die	Production
CGY2173UH/C2	6 - 18	6	12	360	6	0 / -3	Die	Production
CGY2172XAUH/C1	8 - 12	6	8	360	2	0 / -5	Die	Production
CGY2172XBUH/C1	8 - 12	6	8	360	3	0 / +5	Die	Production
CGY2392SUH/C1	6 - 18	6	10,8	360	1,7	0 / +5	Die	Sampling
CGY2174UH/C1	13 - 16	6	8	360	6	0 / -3,3	Die	Production

Performance Table for Digital Attenuators functions								
Part number	Operation Frequency (GHz)	Resolution (bits)	Insertion Loss (dB)	Atten Range (dB)	RMS Atten Error (dB)	Ctrl interface (V)	Package	Status
CGY2176AUH/C1	1 - 8	6	5,6	31,5	0,2	0 / +5	Die	Production
CGY2171XAUH/C1	1 - 15	6	5	31,5	0,25	0 / -3	Die	Production
CGY2171XBUH/C1	1 - 15	6	5	31,5	0,25	0 / +3	Die	Production
CGY2390SUH/C1	6 - 18	6	4	35	0,2	0 / +5	Die	Sampling
CGY2169UH/C1	10 - 18	6	4	23,5	0,4	0 / -3,3	Die	Production



# OMMIC

## Foundry Services & III-V Processes

On site Epitaxy and Custom wafers processing **PAGE 13-14**

ED02AH 0.18um E/D GaAs pHEMT **PAGE 15**

D01PH 0.13um GaAs pHEMT **PAGE 15**

D01MH 0.13um GaAs mHEMT **PAGE 16**

D007IH 70nm GaAs mHEMT **PAGE 16**

D004IH 40nm GaAs mHEMT **PAGE 13-14**

DH15IB 0.15um InP/HBT **PAGE 17**

D01GH 100nm GaN/Si **PAGE 17**





OMMIC is a supplier of InP, GaN and GaAs based MMIC circuits and services to the Professional the Telecom, Space and Defense markets and MOCVD based Epitaxial Wafers to the Merchant Market. Our on site epitaxy serves High performance low cost PHEMT, MHEMT & HBT epitaxial wafer supply to large volume GaAs fab.

**Processes and Technology:**

OMMIC has three principal HEMT processes in full production and we have been introducing other processes including mHEMT and HBT. These services enable cut-off frequencies as high as 400 GHz via the mHEMT technology. The latest processes include GaN-on-silicon 100nm. Another newly released process is D025PHS which is a 250nm pHEMT D mode, enabling high power from C to X band (12W at 10GHz).

Process Name	Type	Gate length (µm)	Status	Comments
ED02AH	pHEMT	0.18	Full Production	60 GHz E/D mode
D01PH	pHEMT	0.13	Full Production	100 - 180 GHz power D-mode
D01MH	mHEMT	0.1	Full Production	150 -250 GHz Power D mode
DH15IB	HBT	1.5	Released	180 - 220 GHz InP HBT
D007IH	mHEMT	0.07	Released	300 GHz low-noise, D-mode
E01MH	mHEMT	0.1	Development	200 GHz E mode
D004IH	mHEMT	0.04	Development	400-600 GHz low-noise, D mode
DH05IB	HBT	0.5	Development	250-300GHz InP HBT
D025PHS	pHEMT	0.25	Released	60 GHz power D mode
D01GH	GaN/Si	0.1	Development	100 -200 GHz power D-mode

OMMIC’s InGaAs mHEMT process contains up to 80% indium in the InGaAs layer. Ommic uses this process to target low-noise and power devices fabricated on GaAs and InP substrates. The High Indium content in the InGaAs channel on a GaAs substrate yields performance equivalent to pHEMT on an InP substrate, with lower costs and easier fabrication.

OMMIC’s RF device catalog includes E/D-mode pHEMT, power pHEMT, general-purpose mHEMT, low noise MHEMT, E-Mode MHEMT and InP DHBT processes. Gate Lengths from 180nm to 70nm with Ft’s from 60 GHz to 300 GHz. The pHEMT and mHEMT devices are processed on GaAs substrate and the HBT devices on InP substrates.

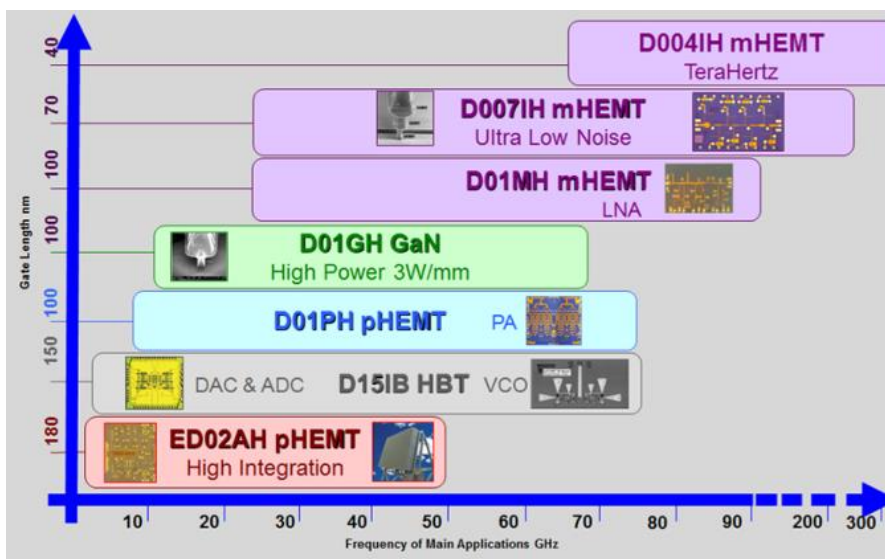

**Epitaxy :**

In addition to a product offering, OMMIC also supplies epi wafers to the merchant market in 3-, 4- and 6-inch formats using production MOVPE.

This activity includes pHEMT containing up to 25% indium in the GaInAs layer, as opposed to 40% that they use internally, as well as HBT structures.

Existing epi processes include :

- GaAs MESFET and HFET
- GaAs and InP based PHEMT
- GaAs/GaInP HBT
- InP/GaAsSb HBT

PHEMT materials are provided with inline capless wafer data.

HBT materials are provided with inline wide area HBT test data



**Roadmap :**

OMMIC has an aggressive roadmap to develop and introduce to the market advanced technologies based on III-V compounds.

This means moving to shorter gate lengths and optimizing the Channel Indium content for the PHEMT and MHEMT processes and smaller emitters and the use of antimonides for the InP DHBT.

The use of the MHEMT technology allows OMMIC to release processes that are truly optimized for high In content fully compatible with 6 inch wafers.

The short gate length technologies include 70 nm 70 % In MHEMTs, and soon 40nm with D004IH process. With 100nm GaN/Si and D025PHS process OMMIC is targeting power applications from X to E band. The roadmap will lead us to develop sub 50nm GaN/Si in the future to target higher power at up to W band

OMMIC's RF device and wafer fab process catalog includes E/D-mode pHEMT, power pHEMT, general-purpose mHEMT, low noise MHEMT, GaN/Si and InP DHBT processes

### ED02AH Process

**0.18 μm PHEMT** – Fully available in Production since 1995  
Optimized for **Low Noise and Mixed Signal** thanks to Enhanced and Depletion transistors.

Well suited for Corechip in phased array antenna application( integration of a serial interface on chip )

**RF and DC Characteristics :**

- Two Threshold Voltages (Vt's) :
  - Enhancement Mode (225 mV)
  - Depletion Mode (- 900 mV)
- Vb<sub>gd</sub> 8 V (typical)
- F<sub>t</sub>'s of 63 GHz and 60 GHz (PCM)
- Full set of passives :  
Epitaxied Resistors, NiCr Resistors MIM capacitors ( 400 pf/mm<sup>2</sup> and 49 pf/mm<sup>2</sup> ), Spirals , Air Bridges, Via holes, Microbumps , Fully passivated Chips with 150nm SiN passivation layer or optional 300nm for packaged devices.

This process is Space evaluated and EPPL listed by ESA.

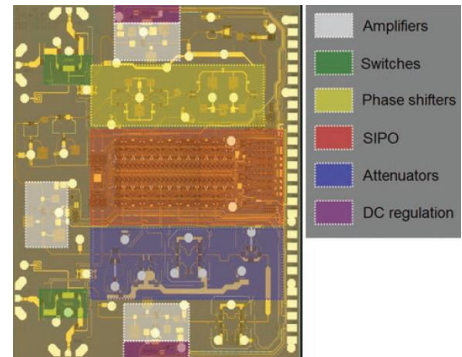

### D01PH Process

**135 nm PHEMT D mode**– Fully available in Production since 1999  
Optimized for **Ultra Low Noise and medium power application from 1GHz to 50GHz.**

Well suited for NF <0.6dB at 2GHz , NF < 1.5dB at 10GHz

**RF and DC Characteristics :**

- Vb<sub>gd</sub> 12 V (typical)
- V<sub>t</sub> of -0.9V
- F<sub>t</sub> of 100 GHz
- F<sub>max</sub> of 180 GHz
- NF<sub>min</sub> at 30GHz of 1dB
- P<sub>1dB/mm</sub>( 40GHz)> 400mW/mm
- Full set of passives :  
Epitaxied Resistors, NiCr Resistors MIM capacitors, Spirals , Air Bridges, Via holes, Microbumps , Fully passivated Chips with 150nm SiN passivation layer or optional 300nm for packaged devices.  
Thickness of 100um with possibility of 70um if special request  
Thick metal option available for optimized noise performances.

This process is Space evaluated and EPPL listed by ESA.

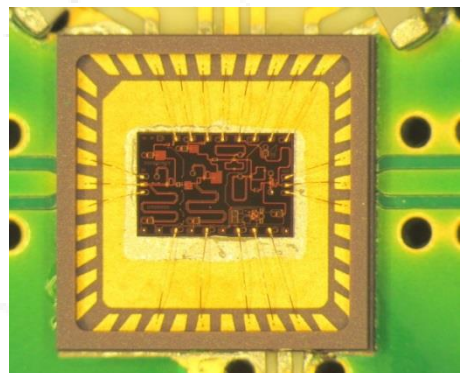
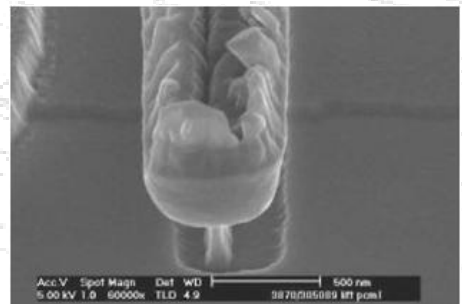

CGY2124HC : X band LNA NF=1.1dB

OMMIC's RF device and wafer fab process catalog includes E/D-mode pHEMT, power pHEMT, General Purpose mHEMT, low noise MHEMT, GaN/Si and InP DHBT processes

### D01MH Process

**125 nm MHEMT** – Fully available in Production since 2010  
Optimized for **Ultra low noise application up to 90GHz**

Well suited very low noise application from Ku to E band such as satcom application or Ka Band guidance systems.

**RF and DC Characteristics :**

- V<sub>bgd</sub> 10 V (typical)
- V<sub>t</sub> of -0.9V
- F<sub>t</sub> of 150 GHz
- F<sub>max</sub> of 250 GHz
- NF<sub>min</sub> at 30GHz of 0.85dB
- Associated Gain at 30GHz of 11.5dB
- Full set of passives :

Epitaxied Resistors, NiCr Resistors MIM capacitors, Spirals , Air Bridges, Via holes, Microbumps , Fully passivated Chips with 150nm SiN.

Thickness of 100um

Thick metal option available for optimized noise performances.

This process is under space evaluation by ESA (to be completed by Q4 2014).

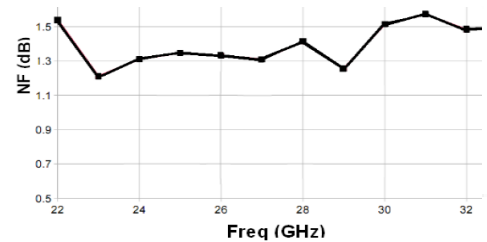
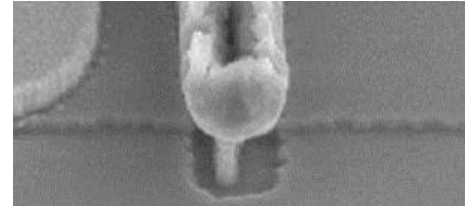

CGY218UH Noise Performances

### D007IH Process

**70 nm MHEMT** – Fully available in Production since 2011  
Optimized for **Ultra Low Noise from 20GHz to 160GHz.**

Well suited for telecommunication , Satcom, Passive Imaging  
Typical 2.8dB noise around 90GHz.

**RF and DC Characteristics :**

- Advanced 70 nm double - mushroom gate
- High In Channel (70 %)
- Outstanding f<sub>t</sub> : 300 GHz
- Very Low Noise : 0.5 dB Minimum Noise Figure at 30 GHz
- Associated Gain : 12.5dB at 30GHz
- F<sub>max</sub> of 450 GHz
- Full set of passives based on D01PH :

Epitaxied Resistors, NiCr Resistors MIM capacitors, Spirals , Air Bridges, Via holes, Microbumps , Fully passivated Chips with 150nm SiN passivation layer or optional 300nm for packaged devices.

Thickness of 100um with possibility

Thick metal option available for optimized noise performances.

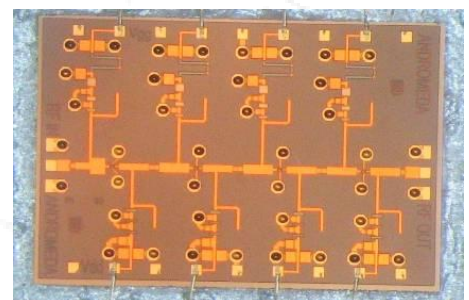

CGY2190UH/C2 : W band LNA  
NF=2.8dB





OMMIC's RF device and wafer fab process catalog includes E/D-mode pHEMT, power pHEMT, General Purpose mHEMT, low noise MHEMT, GaN/Si and InP DHBT processes

### DH15IB InP HBT

**1.5 μm Emitter length D-mode** –Available as Pre-production, prototyping and shared wafer services  
Optimized for VCO and mixers from C to V band

Well suited for High data rate interfaces , TIA, Drivers , very low phase noise oscillators, mixers.

**RF and DC Characteristics :**

- Vce 6 V
- Ft of 180 GHz
- Fmax of 220 GHz

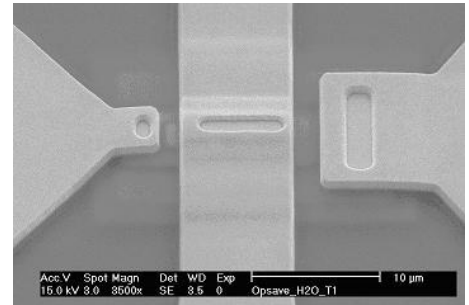

### D01GH GaN/Si Power Process

**NEW**

**100 nm GaN/Si** – Available upon request for design and prototyping Design Kit available. Shared wafer services available Q4 2014.  
Optimized for power application from 20GHz to 94GHz but also for robust Low noise amplifier from 10 to 20GHz.

Well suited for power amplifier design for Ka band Sat application, V band and E band point to point radio or Backhaul.

**RF and DC Characteristics :**

- Vbgd 30 V
- Ft of 95 GHz
- Fmax of 190 GHz
- Power : 3.2W/mm of gate at 30GHz
- PAE : 35%
- Mushroom Gate ( 100nm – 60nm)
- In situ Passivated ( for low lag effect <10%)
- Regrown ohmic contact ( for high Gm)
- Full set of passives like D01PH

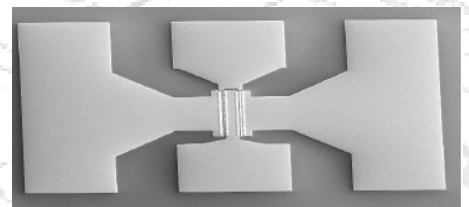
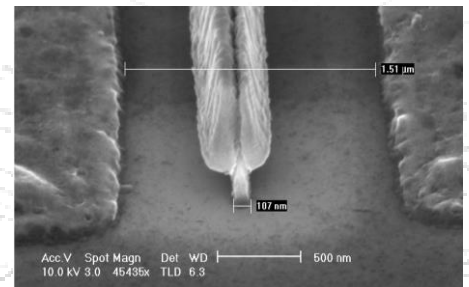

This process is based on 100% European raw material sourcing .

### D025PHS Power Process

**NEW**

**250 nm PHEMT**– Prototyping  
Optimized for power application from 5GHz to 20GHz

Well suited for telecommunication , Civil or Military Radar application or Satcom. Can be used for MMIC design or as stand alone power bars.

**Example of target : 14W Psat in X band**

**RF and DC Characteristics :**

- Vbgd of 16V
- Vt of -0.9V
- ft : 37 GHz
- fmax : 95GHz
- Power: 1.7W/mm of gate at 10GHz



Xband radar ( source US Navy)





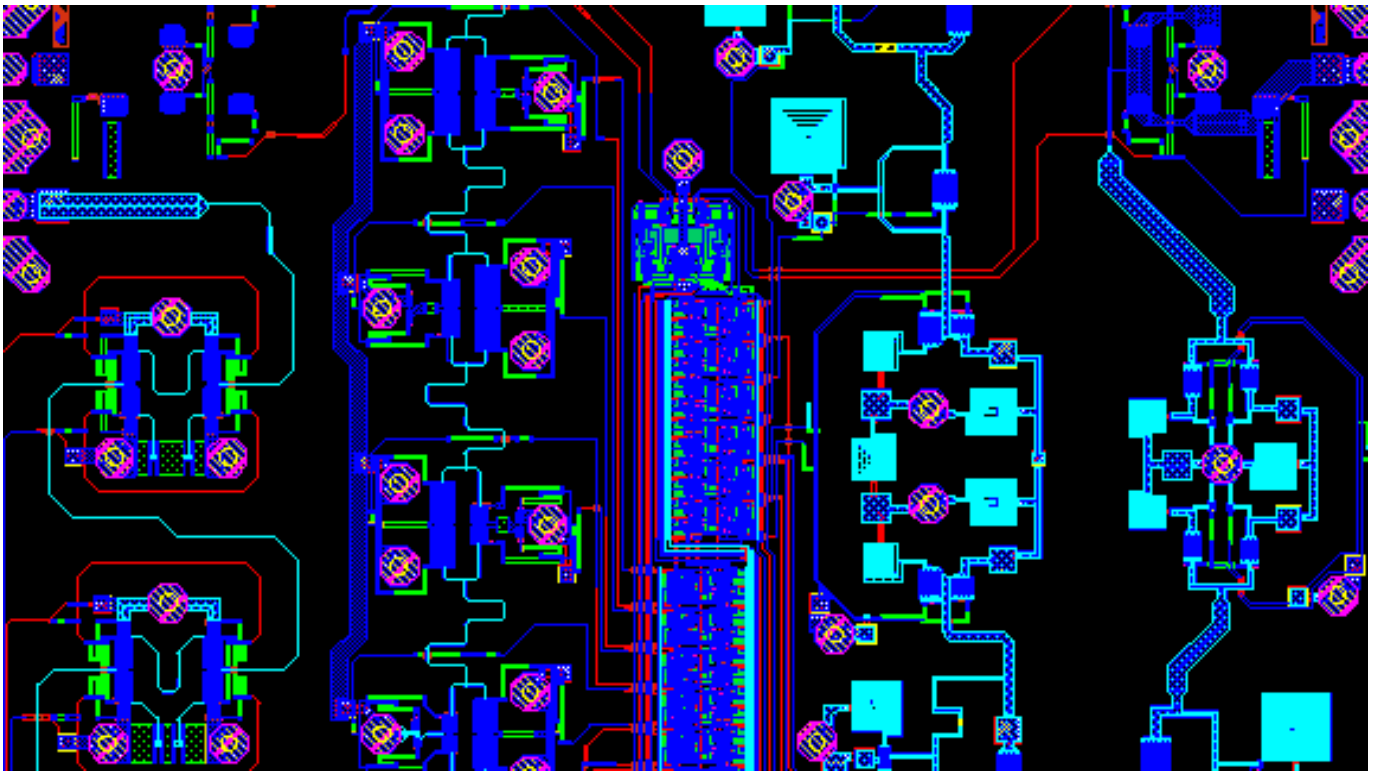

# OMMIC

## Design Center & Fab+

Custom designs team

Challenging designs from 5 to 160GHz

ADS SPICE and AWR design Kits

Multi Chip Projects shared wafers service

Simulation and Extractions for customers

System Models



OMMIC provides services to Customers requiring specific MMICs:

- Open Foundry Service, allowing customers to design their own circuit, with help, training and support from OMMIC
- Custom Design Service: OMMIC designs circuits based on customer specifications

OMMIC has a long history of fully open Foundry Service. All OMMIC processes are available for Foundry Service. This includes ED02AH PHEMT 60 GHz E/D process for Analog/Digital designs, D01PH PHEMT 100 GHz process for power up to millimeter wave, D01MH and D007IH 150 and 300 GHz MHEMT processes for mid power or extremely low noise designs up to 150 GHz or more, DH15IB 175 GHz D-HBT process for high bit rate functions or low phase noise devices.

Most of these processes have completed or are running a Space evaluation (ESA-EPPL). Foundry is available for full wafer runs or MCP (“pizza-masks”)

Nom	Description	Lien de téléchargement
ED02AH	Updated 14 October 2013	ici
DH15IB	Updated 11 January 2013	ici
D01MH	Updated 14 October 2013	ici
D007IH	Updated 27 March 2014	ici
D01PH	Updated	

The image shows several windows from design software. The top window is 'Advanced Design System 2011.01 (Main)'. Below it are 'Microwave Office (EMPEL-Design)' and 'ADS Analysis Solutions' windows. The ADS window displays a circuit schematic, a 3D model of a device, and a graph showing a linear relationship between two variables.

The OMMIC design Manuals and design tools are extremely comprehensive and allow any type of design, from mixed signal to low noise and high power, from DC to sub-millimeter wave.

OMMIC Design Kits include:

- Fully scalable models for all devices
- Linear, non linear and noise models for transistors (and diodes)
- Process statistical variations of all active and passive devices, allowing representative yield analysis
- Temperature effects for all passive and active devices
- Complete auto layout for all devices, including all types of interconnections
- E.M. information allowing advanced analysis
- Design Rules Checking

Design kits are regularly updated, in close collaboration with Software suppliers. OMMIC provides hot line, support, dedicated training and powerful verification tools.

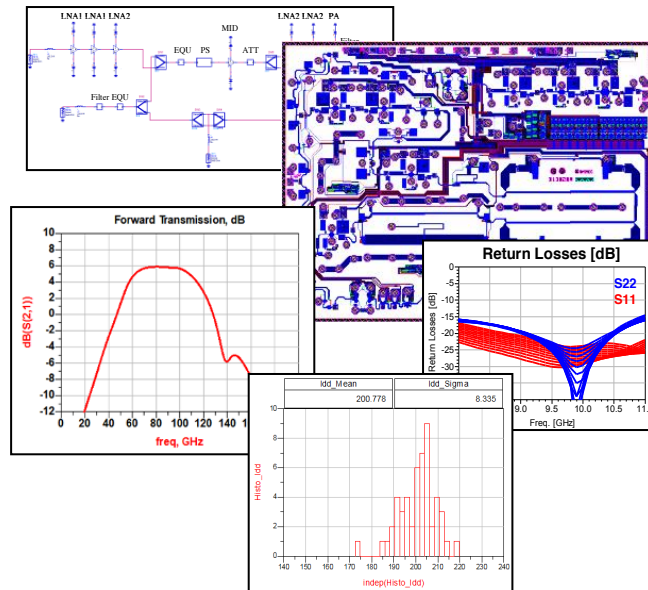

OMMIC design team is able to design MMICs from Customer specifications and Statement of Work.

- LNA
- Power amplifiers
- Multifunction chips including digital parts
- Multipliers
- Down-convertors or TransImpedance amplifiers from DC to W band.

The design flow includes several reviews where close discussions with the Customer ensure that the final MMIC will really enhance the final system.

This design flow is based on space standards such as ECSS-Q60-12A and have been approved for flight model designs.

Thanks to proximity of Fabrication Line, Test Center, Reliability Center and Modeling Team on the same site, OMMIC Design Center is able to obtain the best from all the OMMIC processes, while maintaining yield and reliability.

## Foundry Services: Multi Chip Project

A MultiChip Project (MCP) is a cost effective way to experience a new design topology or a new technology through a limited number of samples. OMMIC offered this service for a long time for his mature proprietary technologies.

### Technologies :

The following list of OMMIC technologies can be used following the MCP projects :

- **D01PH** : Depletion mode PHEMT process with a gate length of 0.13  $\mu\text{m}$  for both power and high frequency designs.
- **ED02AH** : Enhancement and Depletion mode PHEMT process with a gate length of 0.18  $\mu\text{m}$  for analog and mixed analog/digital designs;
- **D01MH** : Depletion mode MHEMT process with a gate length of 0.13  $\mu\text{m}$  for low noise, power and high frequency designs.
- **D007IH** : Depletion mode MHEMT process with a gate length of 0.07  $\mu\text{m}$  for low noise and very high frequency designs.
- **DH15IB** : Double Heterojunction HBT process with a emitter of 1.5  $\mu\text{m}$  for very high speed digital and high frequency RF designs.

### Conditions of use :

- The size of the circuit must correspond to one of the fixed patterns for a MCP project.
- The Layout must be supplied according to a predefined time table available on the web site, by default 4 dates per year.
- MCP order should be placed at least 4 weeks before the announced MCP start date.
- The order need to complain with minimum order value when it is applicable

### Available die sizes :

The following sizes are available for the MCP runs :

	1.5mm	3mm
1mm	A=1.5 mm <sup>2</sup> N=25 dies	A=3 mm <sup>2</sup> N=20 dies
2mm	A=3 mm <sup>2</sup> N=20 dies	A=6 mm <sup>2</sup> N=15 dies

X, Y dimension of the die

A : Surface of the reticule N : Number of dies delivered

Other Die size can be used, please contact OMMIC for special demands

### Support :

Users of OMMIC's normal MCP projects have full access to the MCP Customer Support Hotline during 1 year and get access to the technology design kit though OMMIC website.

Before manufacturing, all projects are checked by OMMIC using the OMMIC design rule checker. DRC's are performed at no extra cost.

### Start Dates :

Multichip runs are programmed at regular intervals. Please contact us or check website to have the dates of the next run starts.

Please see: <http://www.ommic.com/site/mpw-4>

### University Partnership :

OMMIC is committed to give access to its technologies for Educational Purposes to Universities and Educational Establishments. Please contact us for more details.





# OMMIC

## Space Heritage & Flight Models

- State of the art processes for space applicatic
- Space qualified processes
- Wafer and Lot qualification capabilities
- Reliability team dedicated to qualify flight moc
- Products in ESA preferred part list
- More than 30.000 flight model delivered



More than 30 000 MMICs have been supplied for Flight Models. OMMIC has more than 100 000 yrs of accumulated Flight Life time around earth in several space mission and satellites equipments.

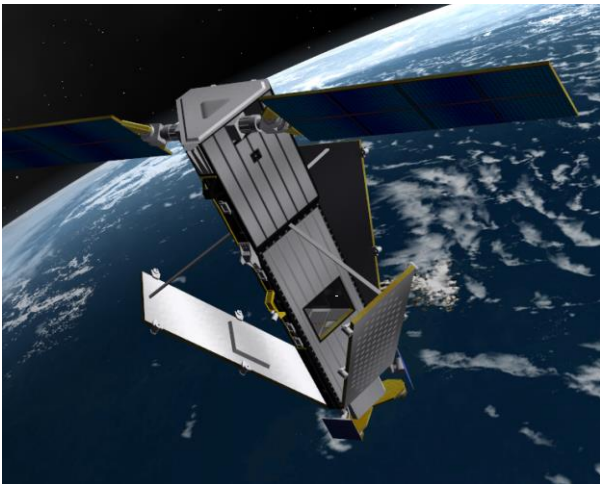

Components from OMMIC have been used in Flight Models for Satellites from Europe, USA, India, Russia and other countries.

Functions include :

- Frequency Converters components as mixers and modulators
- Linear Components as Low Level Amplifiers, LNAs.
- Control Components as Phase Shifters, Attenuators.
- Power Components such as Medium Power Amplifiers
- Non Linear Components such as Frequencies Multipliers,
- Negative Resistor for Oscillators
- Multi-functions components composed by several functions
- Numerical Components as Phase or Frequency Detector.

ESA has already evaluated 2 OMMIC processes ED02AH and D01PH, this 2 processes being maintained on ESA EPPL list. 2 additional processes are considered to be inserted in the EPPL list after ESA monitored evaluation procedures.

OMMIC has already delivered many standard parts designed during the ECI (European Component Initiative) programs.

OMMIC can be a custom design center for space qualified components, many of them have already been designed by the OMMIC's design team of OMMIC.

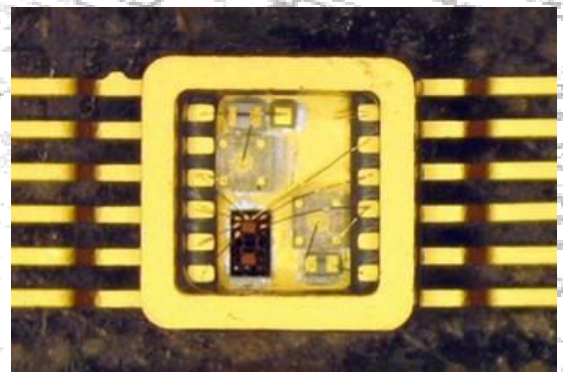

## They have already trusted OMMIC





OMMIC has a dedicated team for space qualification of flight models but also for reliability of all our components.

### Test performed for SPACE EVALUATION FLOW of Flight Model MMICs

All tests below are **Assembly test** for flight models and are performed at OMMIC in our reliability laboratory

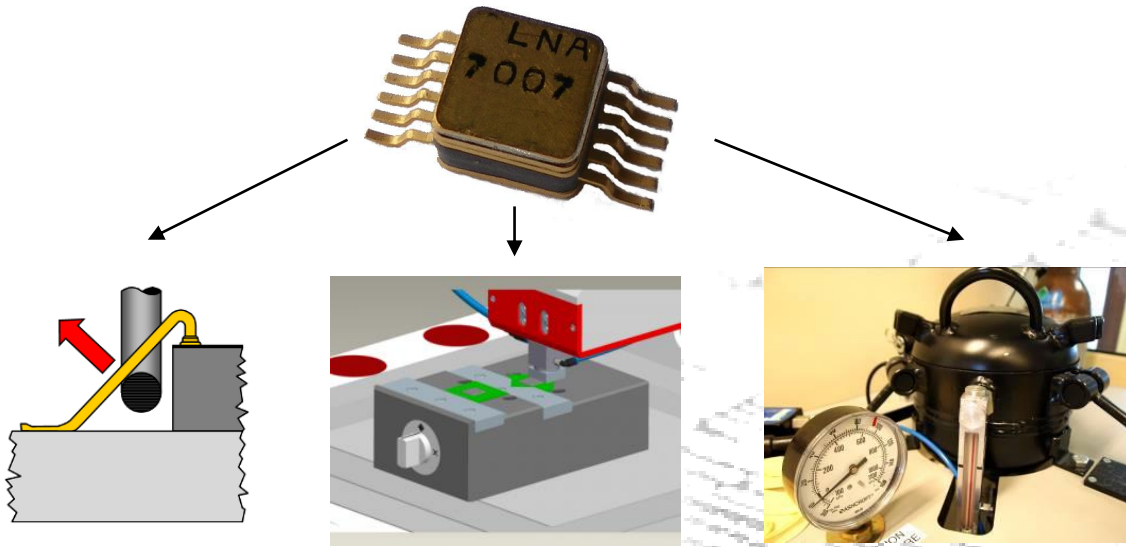

**Bond-pull test**

**Die-Shear test**

**Hermeticity test**

We also perform **Aging and life cycle tests** when requested like in MIL-STD-83 standard



**high temperature DC life test**

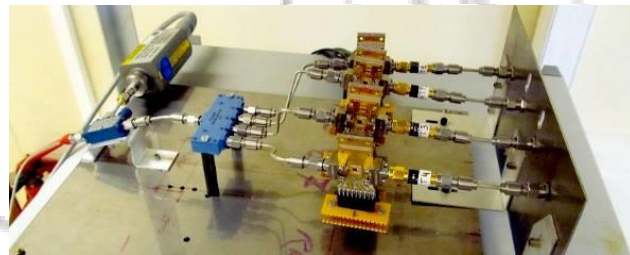

**Room temperature RF stress test**



OMMIC has a dedicated team for space qualification of flight models but also for reliability of all our components.

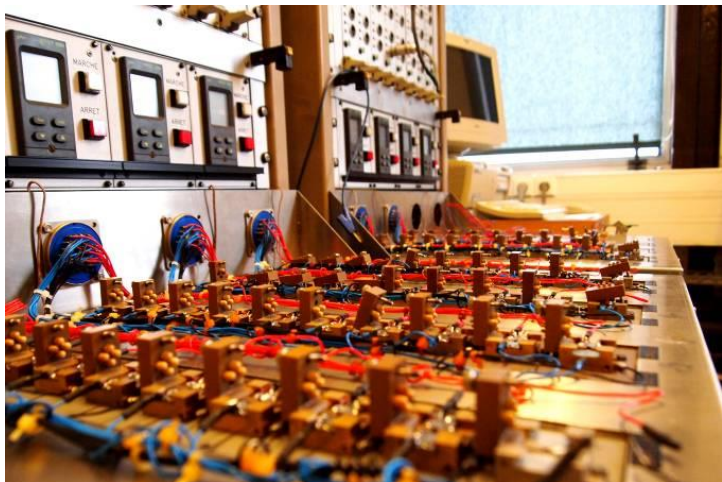
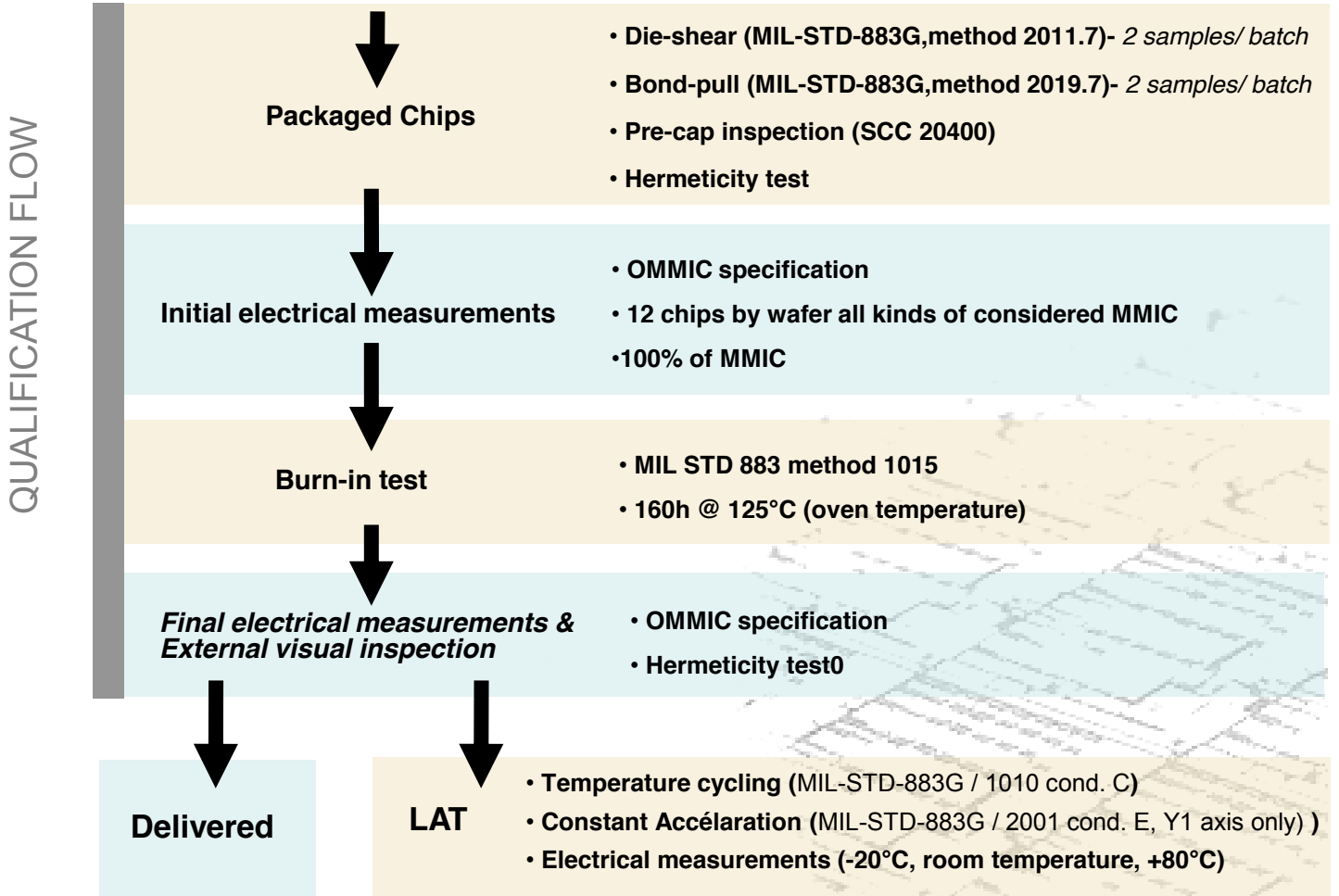

Aging biasing test bench



Burn-in Tests ovens





# OMMIC

## Production Line & and Back-end

- More than 40 years in III-V industry
- Class 10.000 production clean room
- Certified ISO9001 ISO14001 and RoHs compliant
- Standard and Space grade visual inspection
- On wafer test capabilities for microwave & mmW products
- Competitive lead times and maximum flexibility



OMMIC was founded on January 1, 2000 by Philips, based on a track record of 30 years of cutting-edge research and development in the fields of III/V epitaxy and integrated circuits technologies. Today, OMMIC is an independent SME.



OMMIC consists of 5 main buildings of which about 1 000 m<sup>2</sup> is of clean rooms of class 1000 and class 100 which are fully devoted to III-V IC development and fabrication.

Our society delivers MMICS products (standard and custom) : PHEMT 0.18 μm(ED02AH), PHEMT 0.13 μm (D01PH), MHEMT 0.13μm(D01MH) and now MHEMT 0.07μm (D007IH).

Our wafers are delivered with electrical properties guaranteed by the measurement of specific test modules added during the fabrication called PCM (Process Control Monitor).

Our processes and our equipments are followed too with SPC (statistical process control).

Our On-wafer test center disposes of a wide variety of high performance tools and experienced people. It allows us to routinely measure the usual microwave characteristics like Sij, spectrum anal., Scalar meas., Noise figure, DC pulsed meas... All wafers are monitored by DC parametric and RF measurements during the Front End process.

Our experience in micro and mm Wave tests and probe card's design, leads us to design complex tests procedures allowing testing the main performances and functionalities of our MMIC products in order to guarantee the delivery of known good dies. We open to our customers our RF-test capabilities and knowledge to design and conduct tests on their own prototypes, in order to help them to validate and improve their products.

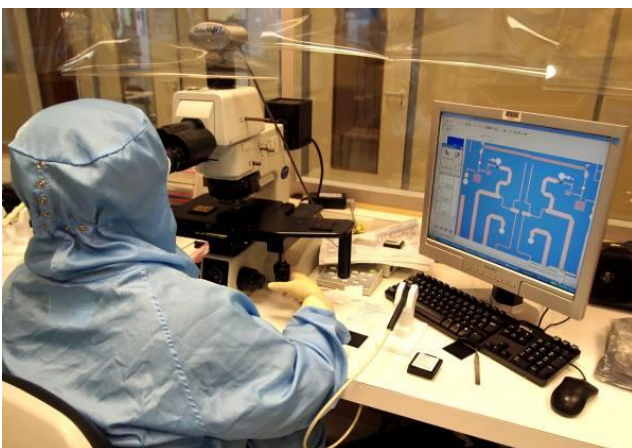
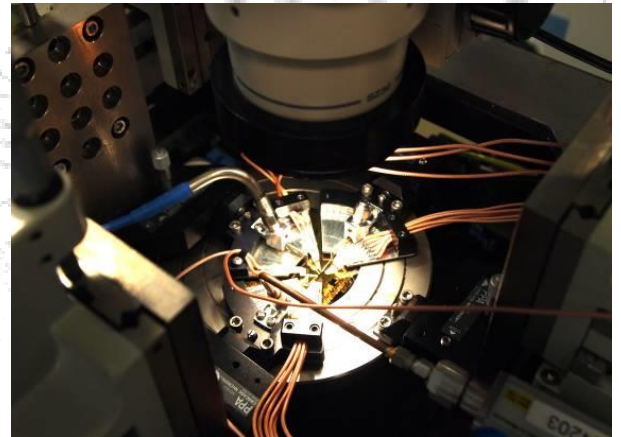

The visual inspection process plays an essential role in our manufacturing steps to ensure anomaly detection to allow us to implement prompt corrective or preventive response and to verify the final quality of each die before sending to our customers.

For this, we performed preliminary visual inspections at each critical step in the production line with sampling and a final visual inspection.

All our products are inspected according to international standards (MIL-STD-883) by a trained and qualified inspection staff. Moreover, for products with less stringent requirements, a commercial grade die inspection is available.

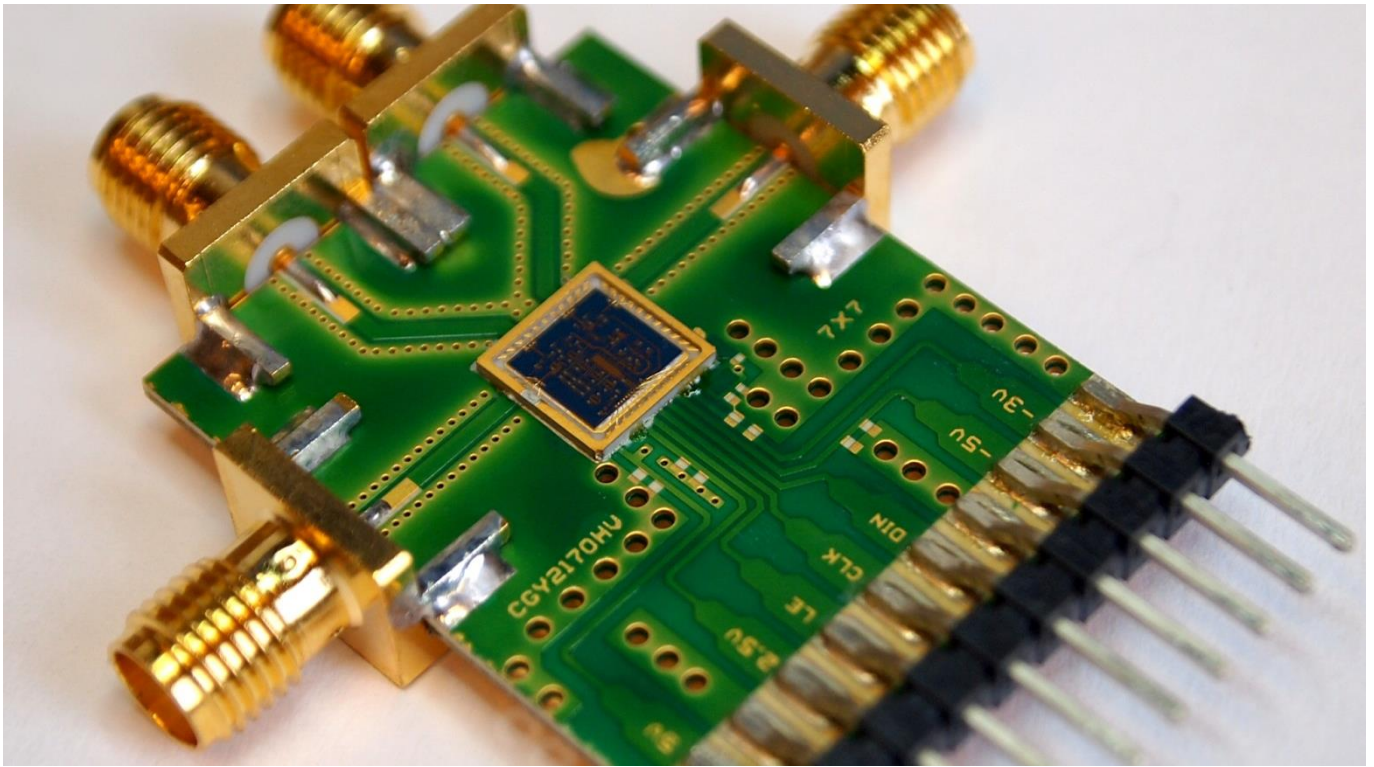

# OMMIC

## Sales support & Application

- Global and dedicated customer support
- System studies support
- On field demonstration upon request
- Mounting support
- Packaging support
- Custom modules design studies



Based in France , in Paris area OMMIC occupies a central position in Europe but also in the world to deliver the right product in the right time to customers. Thanks to its powerful supply chain and reactive regional reps network, OMMIC can support any project in the entire world.

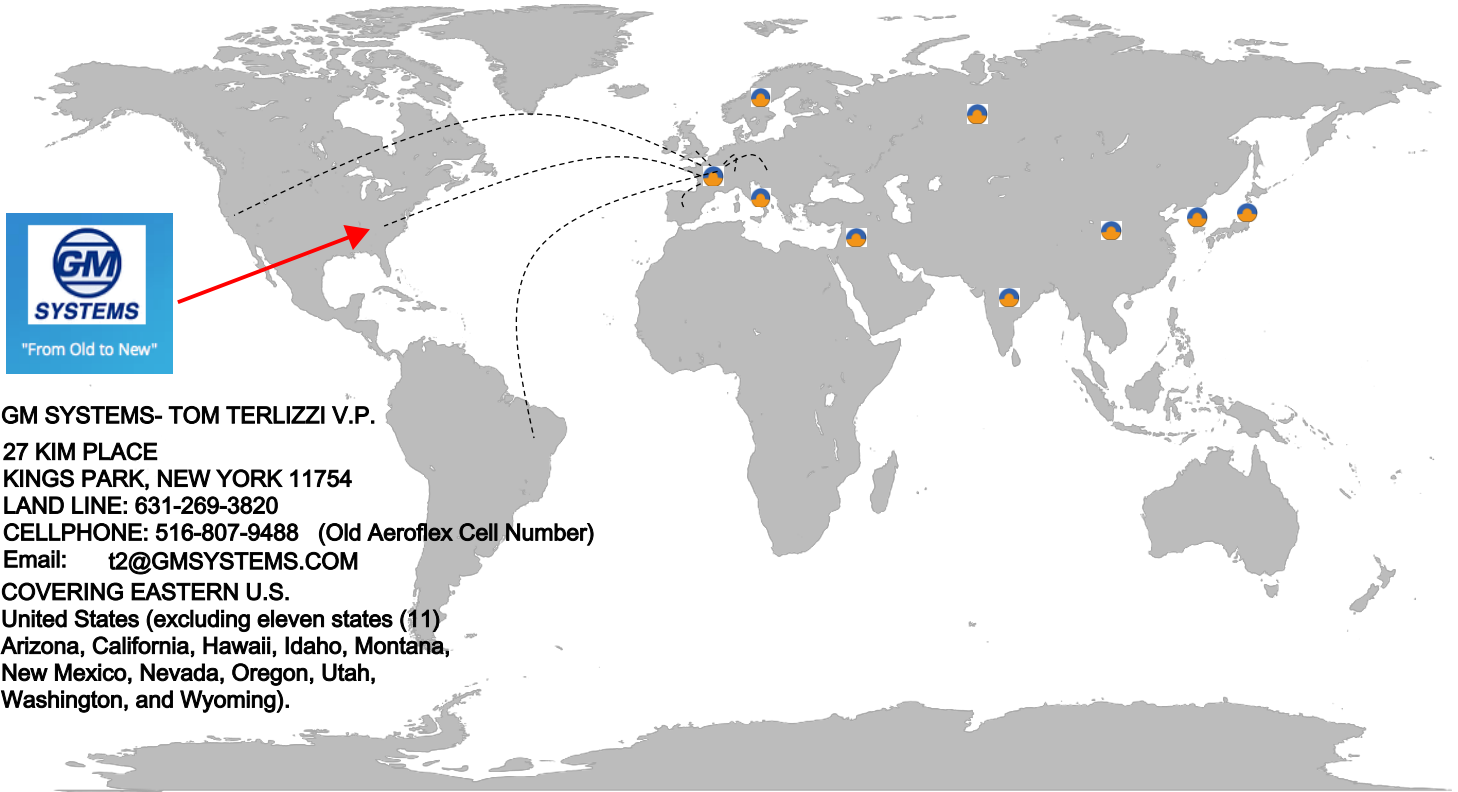

**GM SYSTEMS- TOM TERLIZZI V.P.**  
 27 KIM PLACE  
 KINGS PARK, NEW YORK 11754  
 LAND LINE: 631-269-3820  
 CELLPHONE: 516-807-9488 (Old Aeroflex Cell Number)  
 Email: [t2@GMSYSTEMS.COM](mailto:t2@GMSYSTEMS.COM)  
**COVERING EASTERN U.S.**  
 United States (excluding eleven states (11)  
 Arizona, California, Hawaii, Idaho, Montana,  
 New Mexico, Nevada, Oregon, Utah,  
 Washington, and Wyoming).

**CHINA**  
 ERA Spread Ltd  
[cpfu@eraspread.com](mailto:cpfu@eraspread.com)

**NORTHERN EUROPE**  
 Stowira AB  
[jens.malmgren@stowira.com](mailto:jens.malmgren@stowira.com)

**RUSSIA**  
 Amideon Systems Ltd  
[denis@amideon.com](mailto:denis@amideon.com)

**INDIA**  
 Indo-French High-Tech Equipts  
[brsharma@iheindia.com](mailto:brsharma@iheindia.com)

**SOUTH KOREA**  
 TELCOM  
[shkim@telcom.kr](mailto:shkim@telcom.kr)

**JAPAN**  
 Noah Technology  
[fkato@noah-techno.com](mailto:fkato@noah-techno.com)

**ITALY**  
 Celte S.r.l  
[m.sidoti@celte-srl.com](mailto:m.sidoti@celte-srl.com)

**ISRAEL**  
 American Aviation  
[yoav@amav.co.il](mailto:yoav@amav.co.il)

**For all other countries including USA, Canada, UK, Germany and Spain OMMIC sales in direct.**

Contact us at [information@ommic.com](mailto:information@ommic.com)



A sales and field application team at OMMIC is dedicated to customer sales and technical request to provide the best support in the shortest time

Due to its world class status and human size, OMMIC is a very flexible company able to follow you in your most challenging projects.

You can contact our support team whenever you need at [information@ommic.com](mailto:information@ommic.com)

Or meet us during events such as IMS or EuMW.



## GM SYSTEMS U.S. PARTNERS

GM Systems LLC, headquartered in Kings Park, N.Y. is a technical sales agency providing sales representation for industry leading manufacturers of RF/Microwave and Microelectronic components. GM Systems sales organization has over 100 years of professional sales experience covering microwave communications for commercial, military, aerospace and optical networks. GM Systems experience, product knowledge and reputation make them an exceptional addition to the OMMIC sales and engineering team. GM Systems can be contacted via telephone at (631) 269-3820, or email at [t2@gmsystems.com](mailto:t2@gmsystems.com)



### GM SYSTEMS LLC

TOM TERLIZZI V.P.  
27 KIM PLACE  
KINGS PARK, N.Y. 11754-5025  
516-807-9488 CELL  
631-269-3820 OFFICE  
[terlizzi@gmsystems.com](mailto:terlizzi@gmsystems.com)

UPSTATE NEW YORK, METRO-NYC  
LONG ISLAND, N.J, PA AND  
ALL AREAS NOT COVERED  
BELOW:

#### MID ATLANTIC REGION -MARYLAND & VIRGINIA

George Howell  
President  
ConsultGPH

3446 Everette Dr  
Bowie, MD 20716

Phone: 301 249-0147  
Fax: 301 249-0148  
E-mail: [georgeh@consultgph.com](mailto:georgeh@consultgph.com)

*ConsultGPH*

**H-t-S**  
**High-tech Sales**

#### NEW ENGLAND AREA

Massachusetts, Connecticut, New  
Hampshire, Maine, Rhode Island  
and Vermont

High-Tech-Sales  
Contact: Jay Brewster  
Phone: 603-488-1333  
Email: [jbrewster@htssales.com](mailto:jbrewster@htssales.com)

Contact: Dave Kuzmick  
Phone: 603-864-8902  
Email: [dkuzmick@htssales.com](mailto:dkuzmick@htssales.com)

Website: [www.htssales.com](http://www.htssales.com)

# OMMIC

## Short Form Catalog 2014



GM SYSTEMS  
27 KIM PLACE  
KINGS PARK, NEW YORK 11754  
LAND LINE: 631-269-3820  
CELLPHONE: 516-807-9488 (Old Aeroflex Cell Number)  
Email: [t2@gmsystems.com](mailto:t2@gmsystems.com)

**Address :**

**2 rue du Moulin  
94453 Limeil Brevannes  
France**

**Visit us**

**[www.ommic.com](http://www.ommic.com)**

**Contact us**

**[information@ommic.com](mailto:information@ommic.com)**